

565

Downflow Softener Manual

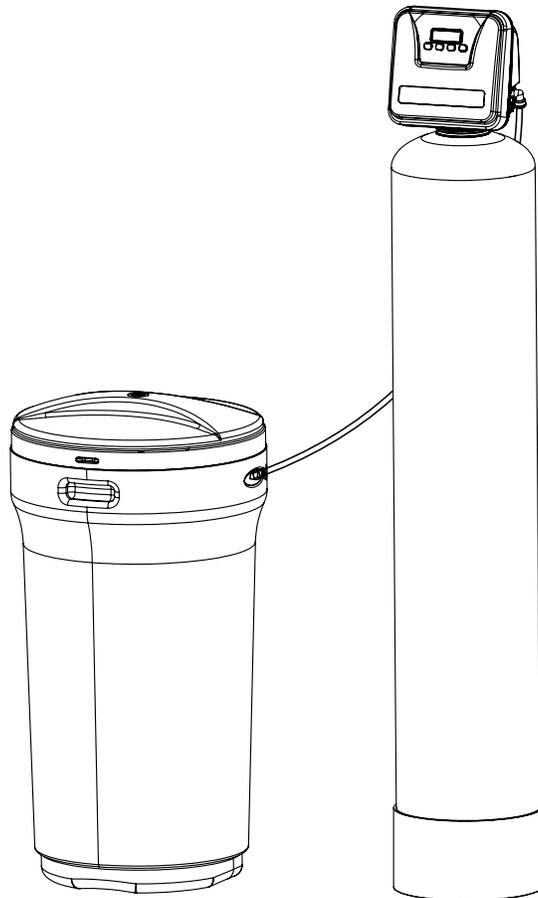

IAPMO R & T Certified
Against NSF/ANSI 44 and
CSA B483.1

1. This manual contains important safety and operating instructions. Read all instructions and follow them when using this product. Failure to consider this information and follow these instructions, including those concerning maintenance, may result in property damage, injury and or death.

Page 24 of this manual contains important maintenance procedures for the continued proper operation of your unit. These MUST be performed regularly for your warranty to remain valid.

2. We recommend installation only be completed by a competent installer or plumbing professional to insure this product is installed in accordance with local plumbing codes.
3. Read this manual in full and follow all instructions carefully before operation.
4. Avoid pinched O-rings during installation by applying NSF certified lubricant to all seals (provided with install kit).
5. This system is not intended for treating water that is microbiologically unsafe or of unknown quality without adequate disinfection before or after the system.
6. Discard small parts remaining after the installation.
7. Failure to install the system correctly voids the warranty.
8. Handle all components of the system with care. Do not drop, drag or turn components upside down.
9. Save these instructions and keep track of your product's serial number.

NOTICE: THIS MANUAL CONTAINS A LIMITED WARRANTY. BY INSTALLING AND OR USING THIS PRODUCT, YOU WAIVE CERTAIN LEGAL RIGHTS INCLUDING THE RIGHT TO SUE OR CLAIM COMPENSATION IN THE EVENT OF PROPERTY DAMAGE, INJURY, AND OR DEATH.

Canature WaterGroup Canada Inc.
855 Park St., Unit 1
Regina, SK, S4N 6M1
Toll Free: (877) 288-9888

Canature WaterGroup U.S.A. Inc.
6353 Commerce Drive
Whitestown, IN, 46075
Toll Free: (877) 288-9888

Table of Contents

SAFETY	4
FIND AND RECORD VALVE TYPE & SERIAL NUMBERS	5
RECORDS & CONTACTS	5
KNOW THIS BEFORE STARTING YOUR INSTALLATION	6
HOW YOUR WATER SOFTENER WORKS	7
FEATURES & TERMINOLOGY	7
FLOW RATE INFORMATION	8
FEED WATER PARAMETERS	8
UNPACKING/INSPECTION	9
BEFORE INSTALLATION	10
PREPARATIONS	11
PLANNING YOUR INSTALLATION	14
INSTALLATION STEPS	16
UNDERSTAND THE SCREEN & KEYPAD CONFIGURATION	18
START-UP INSTRUCTIONS	19
PLUMBING SYSTEM CLEAN UP	23
SANITIZATION PROCEDURE	24
SYSTEM MAINTENANCE	24
SERVICING YOUR CONTROL VALVE	27
TROUBLESHOOTING GUIDE	30
COMMON SPARE PARTS	31
WARRANTY	32

SAFETY

Throughout this manual, certain conventions are used, including;

HAZARD SYMBOLS	
	For your own safety, please pay strict attention! Examples include: temperature, electrical, and water pressure, etc.
HAZARD SIGNALS	
	Indicates a hazardous situation that, if not avoided will result in death or serious injury, and/or property loss or damage.
	Indicates a hazardous situation that, if not avoided may result in death or serious injury, and/or property loss or damage.
	Indicates a hazardous situation that, if not avoided, could result in a minor or moderate injury, and/or property loss or damage
	Indicates important information, that if not followed may result in damage to equipment, or property loss.
WARRANTY EXCLUSIONS	
	Identify specific instructions that, if not followed, will void the warranty. The warranty provided gives you specific legal rights and otherwise limits your legal rights to the extent permitted by law. By installing and/or using this product, you are accepting these limits on your legal rights.
NOTES	
	Help you take full advantage of the system and are used to emphasize installation, operation, or maintenance information that is important but does not present a hazard.
MANDATORY SIGNS	
	Used to depict a specific behavior that MUST be followed to avoid the present hazard (problem).

Canature WaterGroup U.S.A. Inc. / Canature WaterGroup Canada Inc. (“Canature”) has disclosed all known risks associated with the product within this manual but cannot disclose risks that are beyond its knowledge.

Original instructions. All information, illustrations, and specifications in this manual are based on the latest information available at the time of the publication.

The right is reserved to make changes at any time without notice.

FIND AND RECORD VALVE TYPE & SERIAL NUMBERS

There are two labels located on your Unit: **1) Control valve label** and **2) System number label**. Find and record your product model number, serial number, and valve serial number in the **Records & Contacts** section as they will be important if you need to troubleshoot.



Control Valve Serial # _____

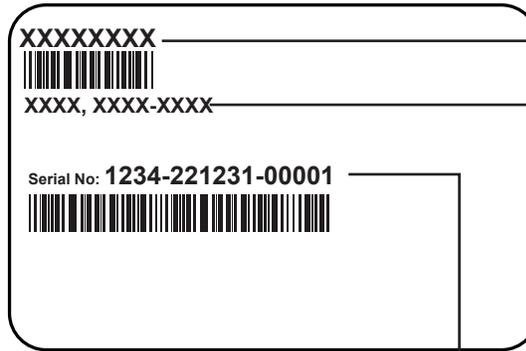

System Serial # _____

Item # _____

Model # _____

NOTE

For cabinet models, the model number and the system serial number are located under the salt lid.



NOTE

Do NOT remove or destroy the serial number. It MUST be referenced on request for warranty repair or replacement.

RECORDS & CONTACTS

Please have the information below filled out and available when calling in for parts or warranty:

YOUR DEALER:

Name: _____

Address: _____

Phone: _____

Other: _____

YOUR SYSTEM:

Model number: _____

Serial number: _____

Valve Serial number: _____

Date installed: _____

Installed by: _____

NOTES: _____



KNOW THIS BEFORE STARTING YOUR INSTALLATION

- ▶ Read this manual thoroughly to become familiar with the softener and its capabilities before installing or operating.



Failure to follow instructions could result in personal injury, property damage or death.

This manual will assist you in getting the most out of your new softener.

- ▶ The installation of this softener **MUST** be in accordance with all electrical and plumbing authorities, as well as all applicable local codes and ordinances.

Check with your local public works department for plumbing and sanitation codes.

In the event that the codes conflict with any content in this manual – the local codes should be followed.

Installation by a licensed plumber or certified water treatment professional is recommended.



- ▶ This softener is designed to operate on pressures of 30 -125 psi.

If the water pressure is higher than 125 psi, use a pressure reducing valve ahead of this softener.

- ▶ It is not uncommon for sediment, precipitated iron, or hardness to be present in water supplies. Precipitated minerals or sediment can cause damage to the seals and piston.



If precipitated minerals or sediment are present in your water supply this will be considered a harsh environment. The seals and piston would not be covered by warranty, stated or otherwise.



- ▶ Do NOT use water that is microbiologically unsafe without adequate disinfection before or after this system.

- ▶ This softener is capable of operating at temperatures between 4 °C – 43 °C or (40 °F -110 °F).



Do NOT expose softener to freezing temperatures or vacuum.

Discharge lines exposed to freezing temperatures should be positioned with a downward slope.



- ▶ Do NOT expose softener to direct sunlight.



- ▶ Do not use this softener on hot water supply lines.
- ▶ Avoid pinched O-rings during installation by applying the silicone-based lubricant supplied. Part #92360.
- ▶ It is recommended to inspect and service the control valve on an annual basis.

Cleaning and or replacement of piston, seals, and or spacers may be necessary depending on the raw water quality.

Your installer can provide a maintenance kit for this purpose.

- ▶ Rural applications should have a water analysis annually prior to system checkup or repair.



- ▶ Chlorine bleach and common iron control chemicals may generate toxic fumes when mixed.



- ▶ Always wear appropriate safety gear, such as safety glasses.

NOTICE

The warranty provided gives you specific legal rights and otherwise limits your legal rights to the extent permitted by law. By installing and/or using this product, you are accepting these limits on your legal rights. Canature is NOT responsible for losses, injury, or death resulting from a failure to observe these safety precautions, or misuse or abuse of the equipment.

NOTE

Check with your local public works department for applicable local plumbing and sanitation codes. Follow local codes if they differ from the standards used in this manual. Otherwise, carefully follow the instructions in this manual. Canature is not liable for any non-compliance with local requirements

HOW YOUR WATER SOFTENER WORKS

Water softeners remove problem minerals (calcium and manganese) causing hardness, from your water by exchanging them with harmless sodium ions in a process called ion exchange. Unlike calcium and magnesium, sodium does not form scaling. Sodium also does not interfere with the cleaning action of soaps. Resin beads charged with sodium ions release the sodium and exchange them with the hardness ions. The resin beads and the softener must be regenerated as these ions are exchanged and are used up.

Regeneration is accomplished by rinsing the resin with a saturated brine solution that removes the calcium and magnesium from the resin bead while replenishing the sodium. This is why the softener requires a brine tank and salt. The water softener will provide soft water for several days before needing to be regenerated when sized correctly for your application. Your system measures the amount of water used to determine when regeneration is required.

This softener is equipped with an internal automatic bypass which will allow for untreated water to bypass the unit during a regeneration so the home will not be without water during this period. Regeneration time is factory set for 2:00 a.m. to minimize the chance of untreated water getting into your system during regeneration. Please try to avoid use of water during this time period or adjust the regeneration time to a suitable time period when water use is at its minimum. Use of water during the regeneration time will result in hard untreated water being used.

FEATURES & TERMINOLOGY

Scrolling Diagnostics

By pressing any button to light the LCD display, the unit will automatically begin scrolling important information for diagnostic purposes.

Remaining Gallons

The amount of soft water capacity until the next regeneration is required.

Number of People

Living in the household as programmed during installation. The installer usually sets this for the worst case hardness.

Reserve Capacity

Calculated at seventy-five (75) gallons per person.

Total Gallons

The total amount of soft water the system can produce between regenerations.

Regen Time

Time of day that the softener is scheduled to regenerate.

Estimated Days to Next

Estimation of days to the next regeneration based on current consumption, hardness, and capacity.

Last Regeneration

The date of the last regeneration cycle.

Total Regeneration

The total number of times the softener has regenerated.

Historical Total Gallons

Total gallons treated by the softener.

Overrun Total

How many times soft water recharge was required due to high usage.

Current Flow Rate

It will only display if treated water is running, otherwise, it will read zero (0).

Valve Mode

Current valve setting, such as softener downflow (DF). You can unlock the circuit board as directed and press the down arrow to stop the scrolling. You can then use the down arrow to go to each of the diagnostics as required.

System Bypass

All systems come with a manual bypass valve which allows you to bypass the 565. This allows raw untreated water to be used in your home for any reason, including system servicing.

Hardness

This can be adjusted seasonally if needed. The installer usually sets this for the worst case scenario, where water hardness fluctuates.

Peak Flow

Maximum flow that has gone through the softener.

Manual Regen Delay

Generally, used after servicing the valve so that it will regenerate at a standard pre-set time.



FLOW RATE INFORMATION

At the stated service flow rates, the pressure drop through these devices will not exceed 15 psig.

Peak flow rates are intended for intermittent use only (10 minutes or less) and are for residential applications only. Do not use peak flow rate for commercial applications or for a continuous rate when treated water supplies are geothermal heat pump, swimming pool, etc.

For satisfactory operation, the pumping rate of the well system must equal or exceed indicated backwash flow rate.

FEED WATER PARAMETERS

Maximum Iron** = 2.0 ppm ferrous (clear water iron)

Maximum Hydrogen Sulfide = 0.0 ppm

Maximum Manganese = 0.75 ppm ferrous (clear water)

pH = 6.5 to 8.5 with **no** iron or manganese present

pH = 6.5 to 7.5 with iron or manganese present

****See System Maintenance Section - Resin Cleaner**

UNPACKING/INSPECTION

Be sure to check the entire unit for any shipping damage or parts loss. Also note damage to the shipping cartons. Contact the transportation company for all damage and loss claims. **The manufacturer is not responsible for damages in transit.**

Small parts, needed to install the softener, are in a parts box. To avoid loss of the small parts, keep them in the parts bag until you are ready to use them.

What is included in the box?

For Models 075,100,150, 200, 250, 300 you will expect the following:

1. Control Valve*
2. Pressure Tank
3. Parts Box
4. Brine Tank Assembly
5. Drain Hose & Clamp (Not included in some brands)
6. Owners Manual

***All units (75, 100, 150, 200) are pre assembled with control valve installed on the tank, no assembly required.**

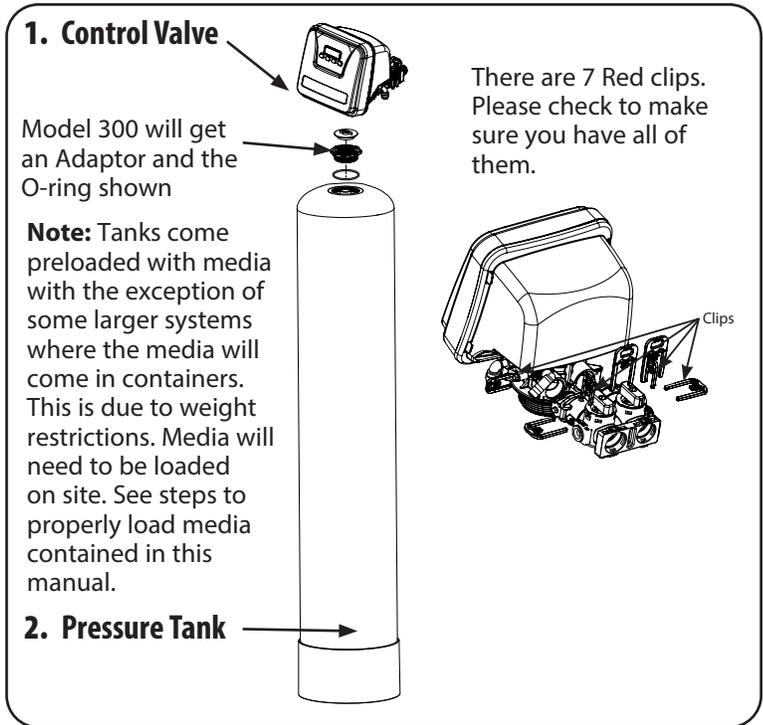
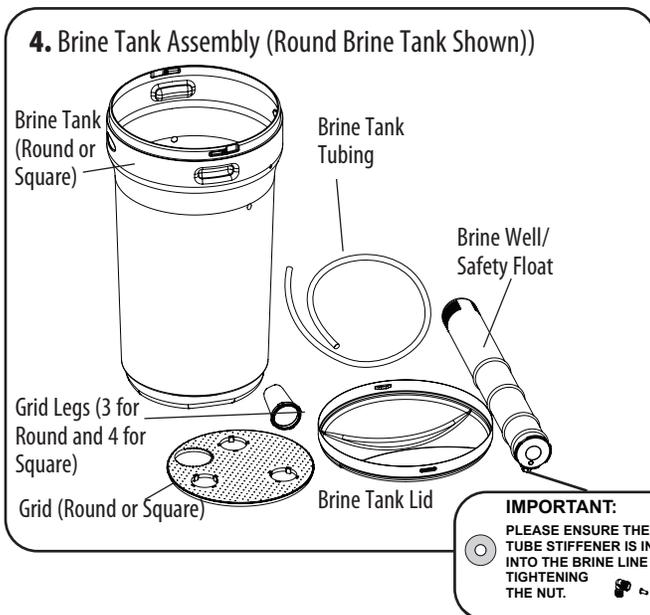
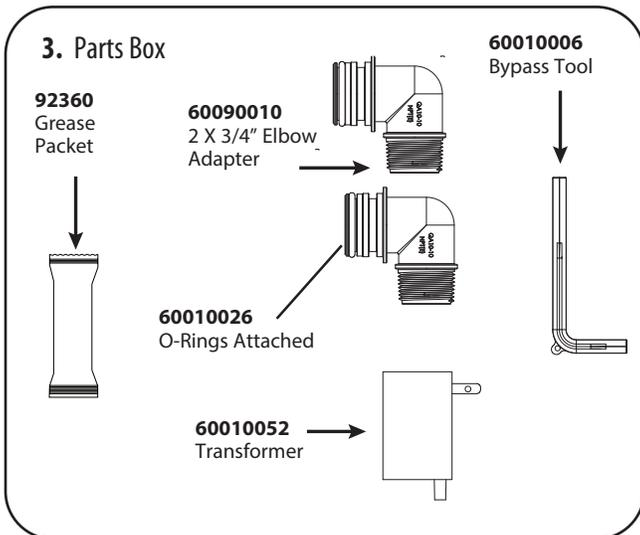

NOTE

Due to transportation and climatic conditions, all connections, including the valve to the tank, need to be checked at time of installation and hand tightened, where necessary.

NOTE

Canature is NOT responsible for damages in transit.

WARNING

RISK OF CHOKING

Discard all leftover parts and packaging materials after installation. Small parts could be a choking hazard.

BEFORE INSTALLATION

Make sure you have a copy of your most recent water test results. If your water has not been tested previously, your professional installer can obtain a water sample bottle to be sent to one of our facilities for a free analysis. **It is important that this product not be installed until you have this information.**

In all cases where metal pipe was originally used and is later interrupted by poly pipe, or the Noryl bypass valve, an approved ground clamp with physical separation and no less than #6 copper conductor must be used for continuity, to maintain proper metallic pipe bonding.

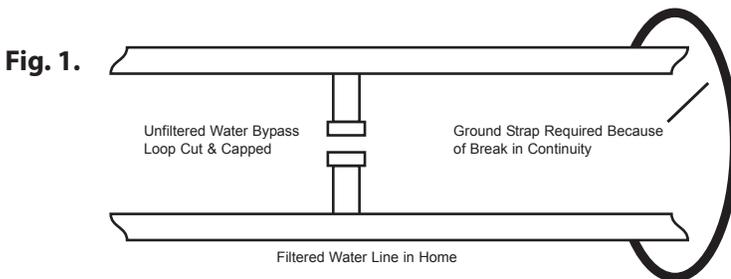

WARNING

If the ground from the electrical panel or breaker box to the water meter or underground copper pipe is tied to the copper water lines and these lines are cut during installation of the bypass valve and/or poly pipe, an approved grounding strap must be used between the two lines that have been cut in order to maintain continuity. The length of the grounding strap will depend upon the number of units being installed and/or the amount of copper pipe being replaced with plastic pipe.

See Figure 1.

MECHANICAL

Do NOT use petroleum-based lubricants such as petroleum jelly, oils or hydrocarbon based lubricants. Use only 100% silicone lubricants (packet Part #92360 provided in parts kit). All plastic connections should be hand tightened only. Thread tape may be used on connections that do not use an O-ring seal.

Do NOT use pliers or pipe wrenches except when indicated by nut shape, e.g., pipe adapters. All plumbing must be completed according to local codes. Soldering connections should be done before connecting any plastic pieces to the pipe as excessive heat can damage them.

Softener resins will degrade in the presence of chlorine or chloramines above one (1) ppm. If you have anything in excess of this amount, you will experience reduced life of the resin. Carbon filtration will help to reduce chlorine/chloramine levels found in today's municipal water supplies, prolonging the life of the resin and providing better tasting, odor free water.

TOOLS REQUIRED FOR INSTALLATION

- ▶ Two adjustable wrenches.
- ▶ Additional tools may be required if modification to home plumbing is required.
- ▶ Plastic inlet and outlet fittings are included with the softener. To maintain full valve flow, use of $\frac{3}{4}$ " or 1" [1.9 cm or 2.54 cm] pipes to and from the softener. You should maintain the same or larger pipe size as the water supply pipe to the softener inlet and outlet.
- ▶ Use copper, brass, or PEX pipes and fittings.
- ▶ Some codes may also allow PVC plastic pipe.
- ▶ $\frac{5}{8}$ " [15.8 mm] Outside Diameter drain line is needed for the valve drain.
- ▶ Drain line tubing may be needed for the optional brine tank overflow fitting.

NOTE

Use of a competent installer or plumbing professional to ensure this product is installed in accordance with local plumbing codes is recommended. Canature is not liable for any non-compliance with local requirements.

PREPARATIONS

MEDIA INSTALLATION (WHEN NECESSARY)

When larger units cannot be loaded due to weight restrictions, media will be shipped pre-measured in separate containers. Follow the steps below for proper media loading.



MANDATORY



Wear a Dust Mask.
Airborne particles could pose potential health risks.

1. Temporarily plug the open end at the top of the riser (distribution) tube with tape.

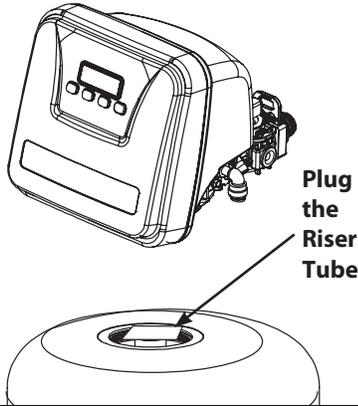

2. Ensure the bottom of the riser tube remains seated in the depression at the bottom of the tank. Fill tank one-quarter full with water to protect the distribution tube during gravel installation.

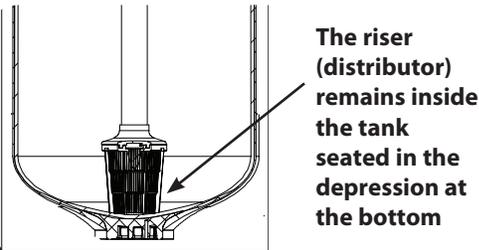

3. Fill the gravel support bed first. A large funnel makes filling the tank much easier. Order part #99003 separately for your own funnel. Slowly add the gravel. Depending on the type of system, add the resin, or media next.

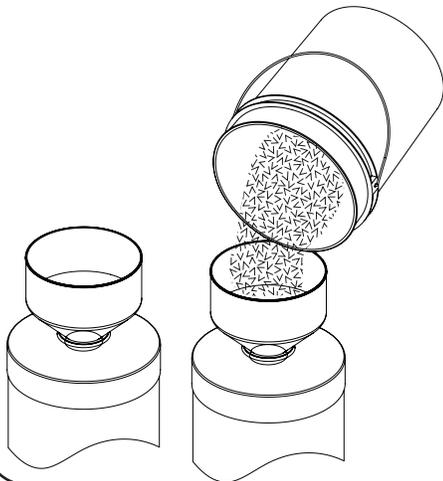

Media →

Support Bed Gravel →

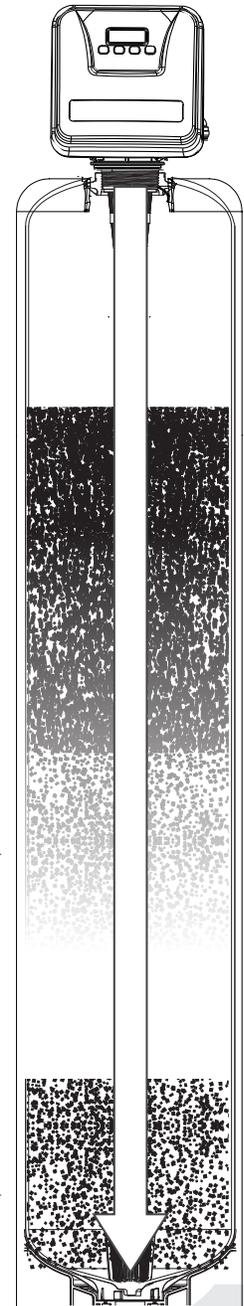

NOTE

If severe loss in water pressure is observed when the softener unit is initially placed in service, the softener tank may have been laid on its side during transit. If this occurs, backwash the softener to 'reclassify' the media.

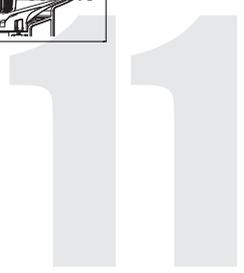

PREPARATIONS (CONTINUED)

4. Apply the supplied lubricant (part #92360) to the internal O-ring at the bottom of the control valve. Apply lubricant to the larger O-ring on the bottom of the valve that seals with the tank threads.

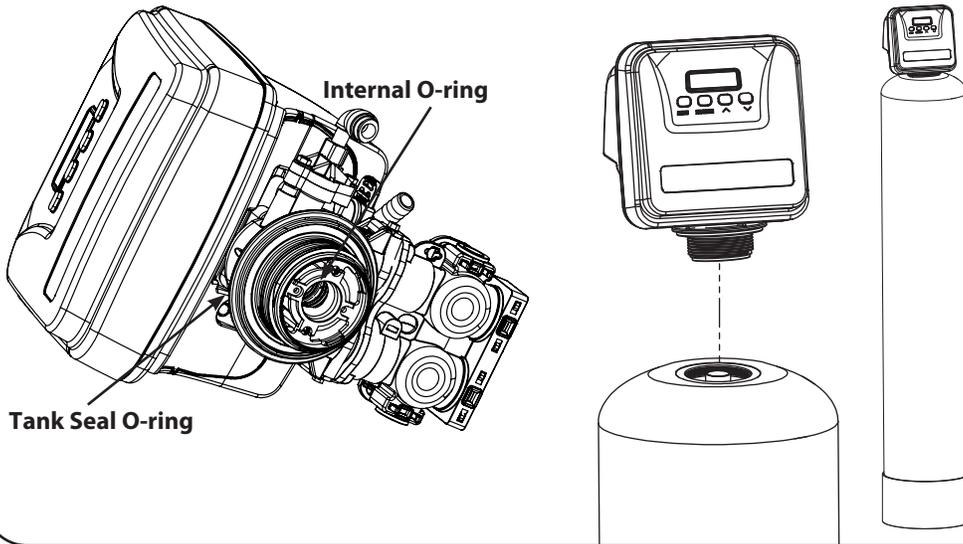

NOTICE

Do NOT use petroleum-based lubricants as they will cause swelling of the O-ring seals.

5. Remove the tape from the top of the riser tube. Carefully position the valve over the riser tube, inserting riser into the internal O-ring. Turn the valve clockwise into the threads of the tank until secure.

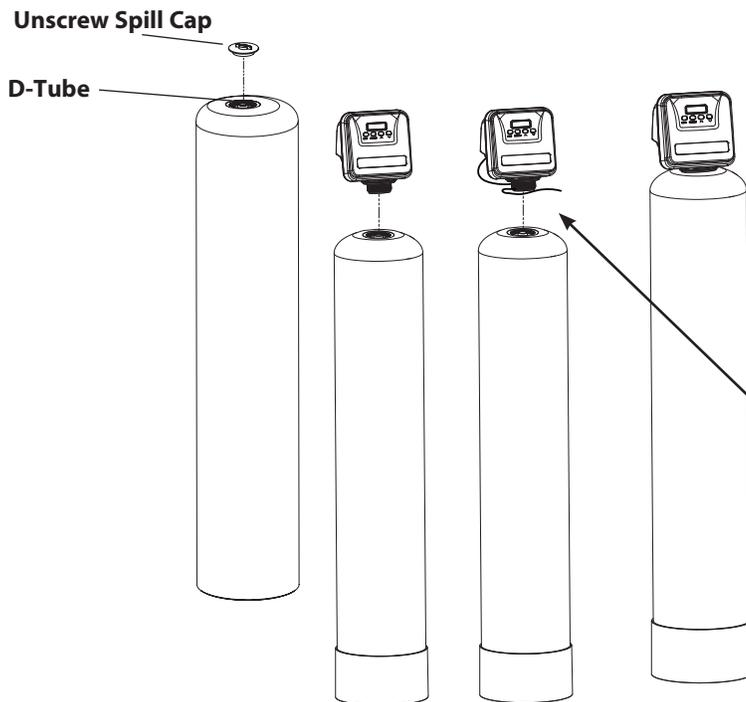

NOTICE

Make sure the quick connect power cord is not yet connected to prevent the cord getting caught between the threads of the tank and the valve.

PREPARATIONS (CONTINUED)

BRINE TANK ASSEMBLY

To assemble the brine tank, (some tanks may be square) follow these steps:

1. Attach the three brine grid legs to grid plate. The legs will snap on to the tabs of the salt plate making a "clicking" sound. Please note, some models will have extensions that are intended to be used as well. (For square brine tank there are four legs.)

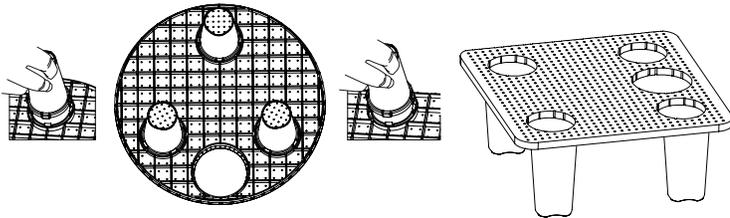

2. Insert the brine well assembly inside and below the grid plate.

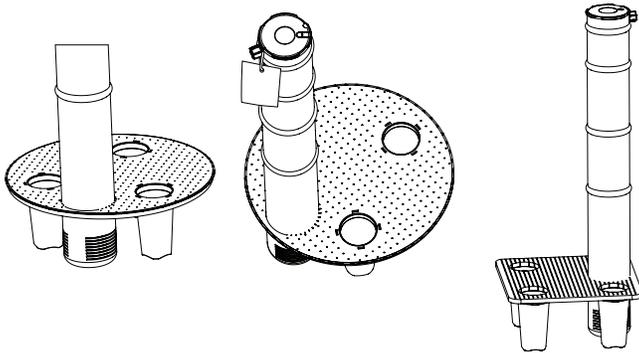

3. Place the brine grid with the brine well inside the brine tank such that the nut fitting faces the hole on the brine tank. Then press the grid evenly inside the brine tank until the brine grid legs and the brine well, as an assembly, touch the bottom of the brine tank.

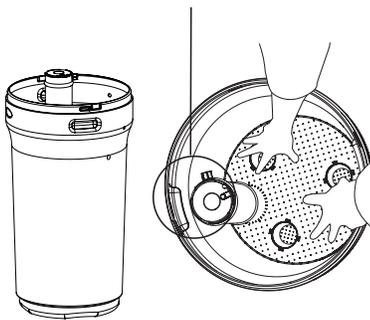

The hole in the brine tank should line up with the brine line as shown for round and square brine tank.

IMPORTANT: IN ROUND BRINE TANK, IT IS IMPORTANT TO ALIGN THE HANDLE TO THE BRINE WELL AS SHOWN.

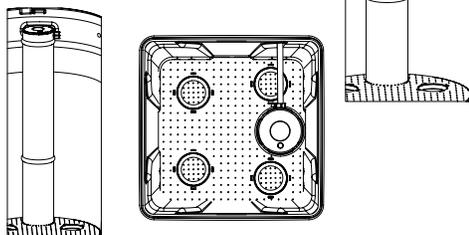

4. Take the brine tube and insert the nut and plastic sleeve as shown below.

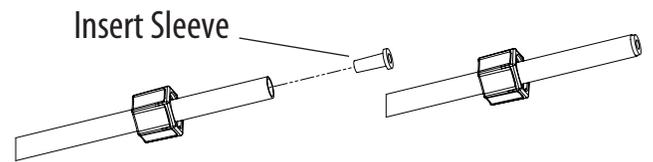

5. Insert the tube in the float assembly elbow and hand-tighten the nut. In many cases the brine line already comes installed from the factory. Leave the other end of the brine line tube inside the brine tank.

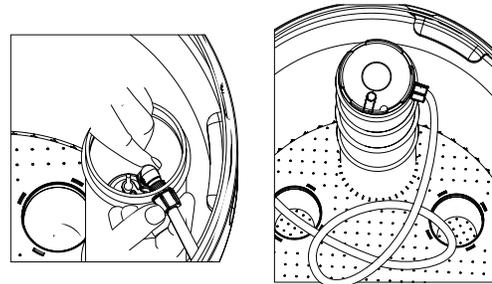

6. For installation of brine tank at the installation site, pull the other end of the brine tube from the hole on the brine tank. The completed assembly is shown below for round and square brine tanks.

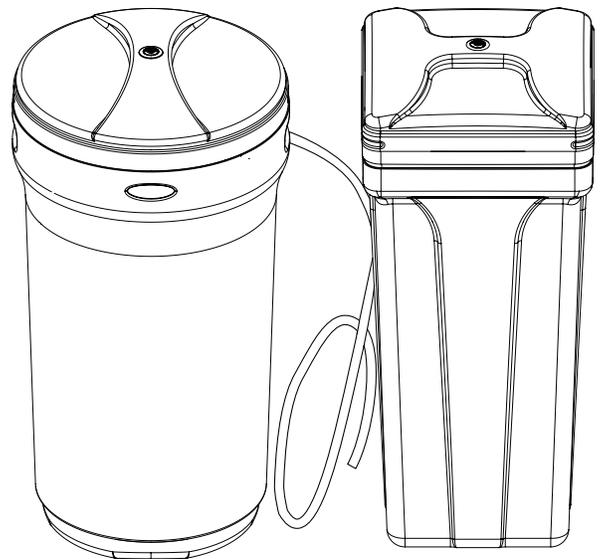

PLANNING YOUR INSTALLATION

WATER SOFTENER INSTALLATION LAYOUT

Select the location for your softener tank with care. Various conditions that contribute to proper location include:

1. All installation procedures must conform to local or regional plumbing codes. Canature is not liable for any non-compliance with local requirements
2. Outside taps used to water lawns and gardens should be isolated from the water line required to supply untreated water to the inlet of the water softener – a separate (new) line may be needed.
3. Where required by local plumbing codes, a check valve may need to be installed. Canature is not liable for any non-compliance with local requirements
4. Locate softener as close as possible to the water supply source.
5. Locate softener as close as possible to a floor or laundry tub drain and a 120 volt AC electrical outlet.
6. Softeners should be located before the water heater on the supply line. If closer than three (3) metres [10 feet], install a check valve in accordance with local plumbing codes.
7. Do NOT install a softener in a location where freezing temperatures occur. Freezing may cause permanent damage to this type of equipment and will void the factory warranty. Freezing could also result in flooding and / or property loss and damage.
8. Allow sufficient space around the unit for easy servicing.
9. Keep the softener out of direct sunlight.

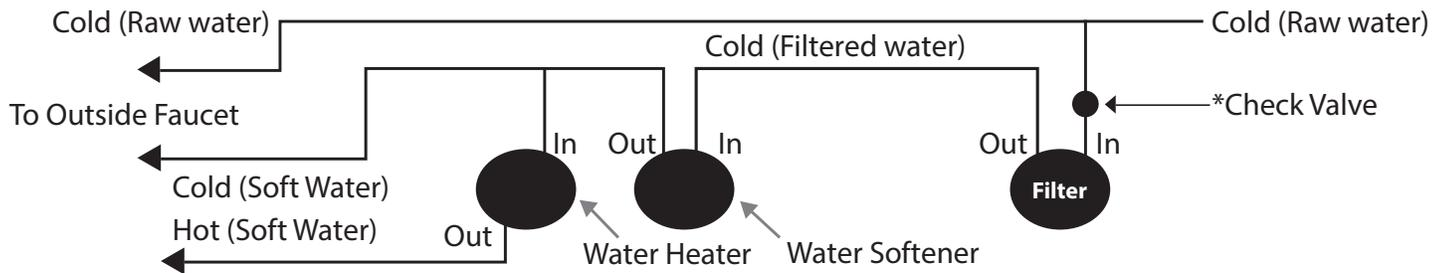

*NOTE

Check local plumbing codes requirements for use of check valve(s), back-flow prevention, or vacuum breakers. Canature is not liable for any non-compliance with local requirements.

PLANNING YOUR INSTALLATION (CONTINUED)

WATER SOFTENER INSTALLATION

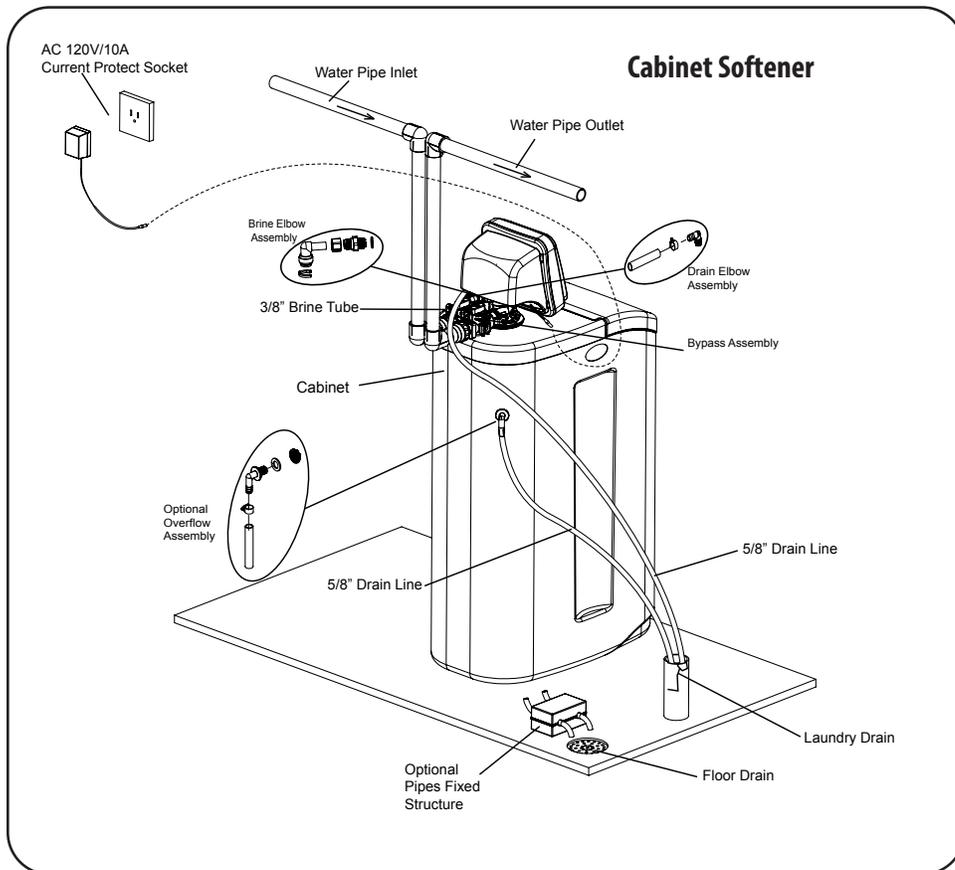
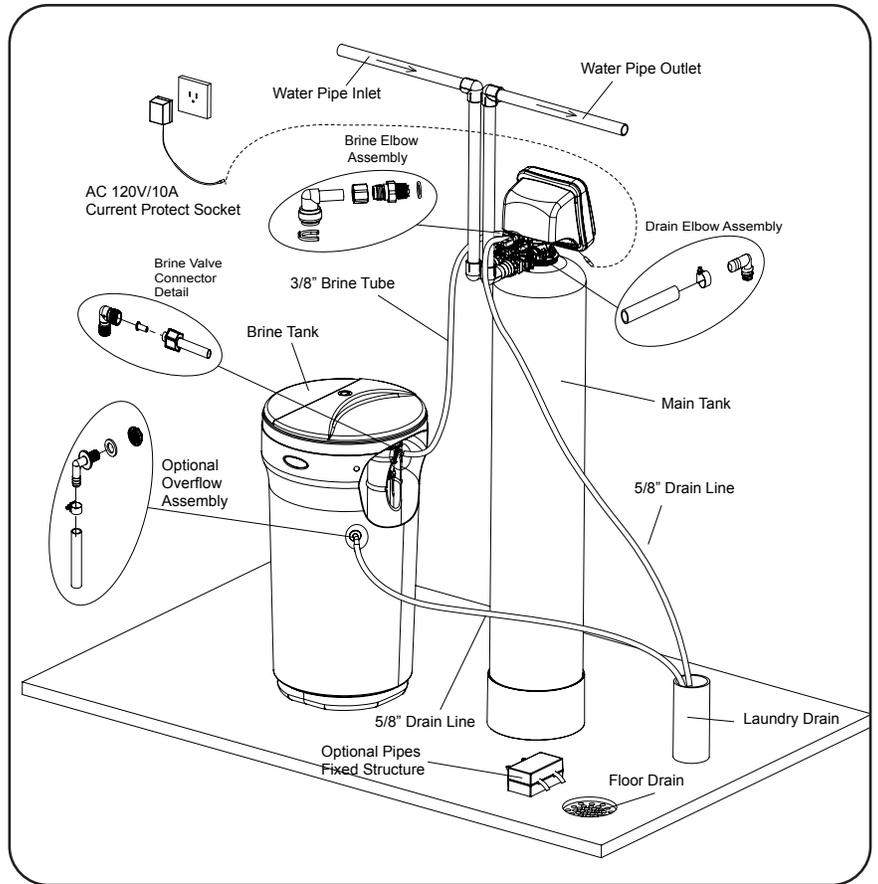

INSTALLATION STEPS

TO BEGIN YOUR INSTALLATION:

1. Make sure the bypass is attached securely to the control valve.
2. Apply thread tape to threaded connections elbow plumbing adaptors
3. Apply the supplied lubricant (#92360) to the O-rings of the fittings.
4. Connect the supplied elbow plumbing adaptors to the bypass with red clips.
5. Connect the inlet and outlet of the water softener to the plumbing of the house.

NOTICE

Any solder joints near the valve must be done before connecting any piping to the valve. Failure to do this could cause damage to the valve.

NOTICE

Do NOT use pipe thread compound as it may attack the material in the valve body.

NOTICE

Failure to leave enough distance could cause damage to the valve. Always leave at least 6" [152 mm] between the valve and joints when soldering pipes that are connected to the valve.

6. For the drain line connection; attach a 1/2" [12.7 mm] Inside Diameter (ID), 5/8" [15.875 mm] Outside Diameter (OD) drain hose to the drain line fitting.
 - a. Run the drain line to a floor or laundry drain.
 - b. Complete any necessary plumbing to maintain a proper air gap.

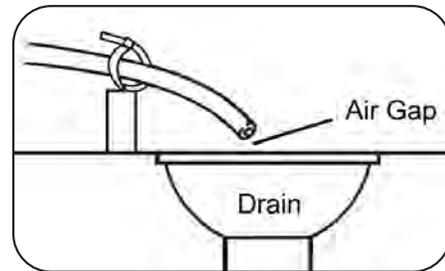

NOTE

The waste connections or drain outlet shall be designed and constructed to provide for connection to the sanitary waste system through an air-gap of 2 pipe diameters or 1" [25.4 mm] whichever is larger.



CAUTION

Never insert drain line directly into a drain, sewer line, or trap. Always allow an air-gap between the drain line and the wastewater to prevent the possibility of sewage being back-siphoned into the softener.

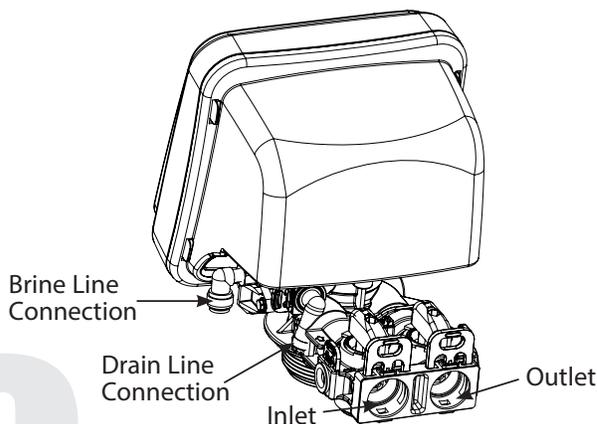

INSTALLATION STEPS (CONTINUED)

7. Attach the brine line from brine tank to brine line fitting on control valve. install the tube stiffener into the end of the brine line before attaching it to the brine line fitting on the control valve See **Fig. 2**.
8. Using the included Allen key, place the unit in the bypass position.
 - a. Slowly turn the main water supply ON.
 - b. At the nearest cold treated water tap, remove the tap screen, OPEN the tap and let water run a few minutes or until the system is free of any air or foreign material resulting from the plumbing work.

Fig. 2. Brine tube stiffener

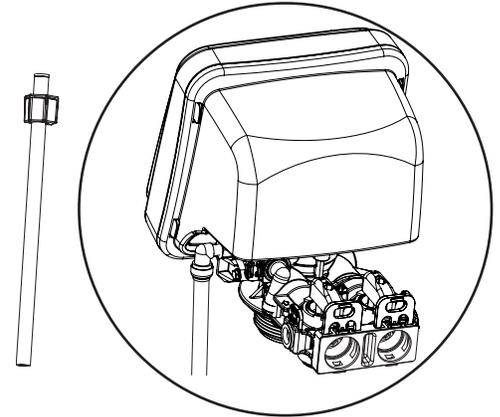

MANUAL WATER BYPASS

In case of an emergency, or to perform softener maintenance, you can isolate your water softener from the water supply using the bypass valve located at the back of the control.

In normal operation the bypass is OPEN with the ON/OFF knobs in line with the INLET and OUTLET pipes, i.e., the black marks in the vertical position. See SERVICE below.

To isolate the softener, simply rotate the knobs as indicated to the CLOSE position until they lock. You can continue to use your water related fixtures as the water supply is bypassing the softener. However, the water you use will be untreated.

To resume treated service, OPEN the bypass valve by rotating the knobs back to the SERVICE position.

NOTE

If the tap has a screen, it should be removed to allow debris to flush out of the plumbing.

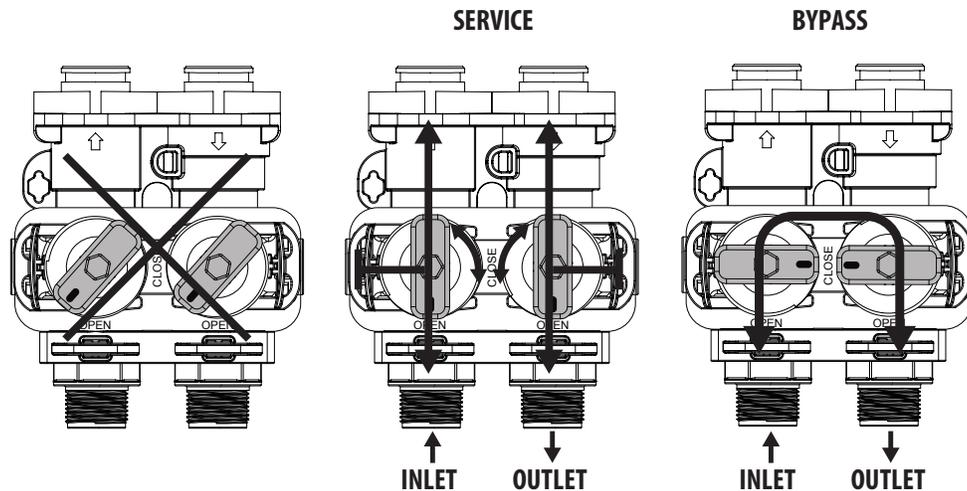

NOTE

Please make sure bypass knobs are completely open otherwise the untreated water may enter through the valve.

9. Make sure there are no leaks in the plumbing system before proceeding. Shut the water tap OFF when the water runs clean.

UNDERSTAND THE SCREEN & KEYPAD CONFIGURATION

The control valve is controlled with simple, user-friendly electronics, displayed on an LCD screen.

CONNECT THE TRANSFORMER



Connect the transformer to the unit by plugging the 12 volt transformer into a 120 VAC 60 Hz outlet.

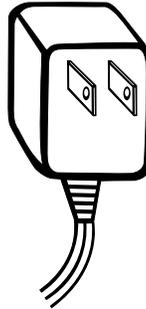
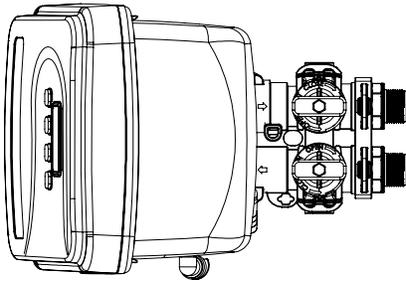

MANDATORY

Do NOT use an outlet that is controlled by a light switch.

When the power is connected, the screen will show the following information in sequence:

1. Date & Time.
2. Total U.S. Gallons, Remaining U.S. Gallons.
3. People Reserve, Reserve U.S. Gallons.
4. Estimated days to regeneration.
5. Last regeneration - last date when system backwashed.
6. Total regenerations.
7. Total treated.
8. Overrun total.
9. Current Flow Rate (GPM) – flow rate of water being currently used.
10. Peak Flow Rate (GPM) – maximum recorded flow rate of the water.
11. Day override.
12. Rinse override.
13. Delayed regeneration.
14. Regeneration Time – time of day when backwash starts.
15. Refill time.
16. Valve mode.
17. Valve ID.

Keypad Legend – the terminology used on the control valve label may vary by model. For the purpose of programming, this manual will use numbers associated with each button position as shown below:

- 1 This function is to enter the basic set up information required at the time of installation.
- 2 This function is to initiate an immediate or delayed manual regeneration.
- 3/4 Increase or decrease the value of the settings while in the programming mode.

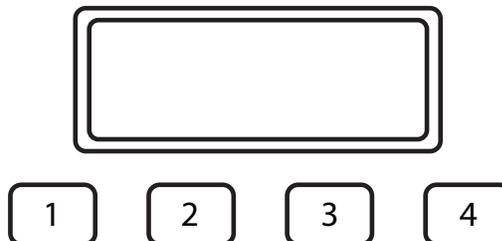

START-UP INSTRUCTIONS

Now that your water softener is plumbed into position it is time to start up and program the unit.

STEP 1. ADD WATER TO BRINE TANK

1. Open the brine tank/cabinet salt lid and fill with water until there is approximately 1" [25.4 mm] of water above the grid plate.
2. If there is no grid plate, fill the tank with 3" [75 mm] of water.

Do NOT add salt to the brine tank at this time.

STEP 2. PURGE AIR FROM THE UNIT



1. Press any button to start. The display may read **PRESS SETTINGS KEY 3 SEC TO UNLOCK** if left untouched for several minutes.

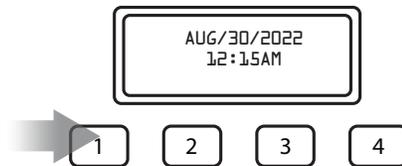

2. To unlock, press **button one (1)** and hold for three (3) seconds. The display will keep confirming unlock.

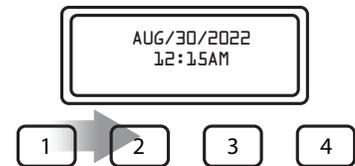

3. Press and hold **button two (2)** to start Manual Regeneration process.



4. Press **button three (3) or four (4)**, choose **REGENERATION IMMEDIATELY**.
5. Press **button two (2)** to start a regeneration cycle.



6. The valve will automatically advance to the backwash position.

NOTE

If severe loss in water pressure is observed when the softener unit is initially placed in service, the softener tank may have been laid on its side during transit. If this occurs, backwash the softener to 'reclassify' the media.

7. **Open the bypass inlet very slowly** until there is a steady stream of water at the drain. Opening the bypass inlet too quickly could result in resin being expelled from the unit and into the plumbing lines. With the valve in the backwash position the unit will purge air from the system, sending it to the drain. This may take longer than the programmed backwash cycle time, so unplug the power so that the valve will remain in the backwash position.
8. With the bypass inlet now fully open, let the system run until all the air is purged and there is a steady stream of water at the drain.
9. Reconnect the power, press button two (2) to advance to the refill position and allow the unit to refill to 1" [25.4 mm] above the grid board or 3" [76.2 mm] of water in cabinet models – this may require manually advancing the unit through its cycles more than once. Alternatively, you can press and hold button 2 (two) to advance to the service position and manually add the required amount of water as described in step 1.
10. Allow the unit to return to the SERVICE position.
11. Slowly open the bypass OUTLET knob until fully open.



MANDATORY

Be sure to open the bypass inlet very slowly. Do NOT FULLY open the bypass inlet until there is a steady stream of water at the drain as this will result in media being expelled from the unit

START-UP INSTRUCTIONS (CONTINUED)

STEP 3. PROGRAM HOUSEHOLD SETTINGS

This unit is factory set for the correct size. You are required to program the date, the time of day, the number of people living in the home and the correct hardness setting. Please review **Compensated Hardness Calculation** before entering the hardness number from your water analysis.

Compensated Hardness Calculation:

___ ppm Iron x 4 = ___ grains of hardness

___ ppm Manganese x 8 = ___ grains of hardness

These numbers can be found on your water analysis report, and the equivalent grains of hardness should be added to your total hardness number. The new sum of these numbers is the hardness to be entered during the programming.

Example

Our water analysis states that our hardness is 15 gpg.

To this we add;

Iron = 0.5 ppm x 4 = 2.0 gpg

Manganese = 0.3 x 8 = 2.4 gpg which we round-up (always) to 3.0 gpg

We use the following hardness equation to derive our total hardness number.

Hardness = 15 gpg + 2.0 (now called compensated iron) + 3.0 (compensated manganese) = 20 gpg.

Enter 20 for total hardness when programming.

20

START-UP INSTRUCTIONS (CONTINUED)

STEP 3. PROGRAM HOUSEHOLD SETTINGS

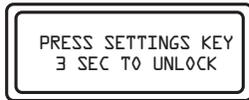

1. The display may read “**PRESS SETTINGS KEY**”. Press **button one (1)** for three seconds (3) to unlock.
2. After three (3) seconds, the display will beep confirming unlock.

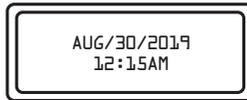

3. Press and hold **button one (1)** for three seconds (3) until you hear a beep. This will unlock the **SETTINGS** menu.



4. Now press **button three (3)** or **four (4)** to change the hour value to current time.

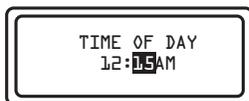

5. Press **button one (1)** once to highlight the next value.



6. Now press **button three (3)** or **four (4)** to change the minute value to current time.



7. Press **button one (1)** once to highlight the next value.



8. Now press **button three (3)** or **four (4)** to change the **AM/PM** value to current time.



9. Press **button one (1)** once to highlight the value.



10. Now press **button three (3)** or **four (4)** to change the **YEAR** value to current year.



11. Press **button one (1)** once to highlight the current month.



12. Now press **button three (3)** or **four (4)** to change the **MONTH** value to desired month.



13. Press **button one (1)** once to highlight **DAY**.

START-UP INSTRUCTIONS (CONTINUED)

STEP 3. PROGRAM HOUSEHOLD SETTINGS (CONTINUED)



14. Now press **button three (3)** or **four (4)** to change the **DAY** value to desired day.



15. Press **button one (1)** once to highlight **SET HARDNESS** value.



16. Now press **button three (3)** or **four (4)** to change **HARDNESS** value.



17. Press **button one (1)** once to highlight **SET PEOPLE** value.



18. Now press **button three (3)** or **four (4)** to change # of **PEOPLE**.

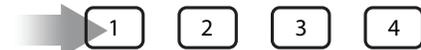

19. Press **button one (1)** once to highlight **SALT SETTING**.

NOTE

This product has had the salt setting factory programmed and locked for correct operation and efficiency. Do NOT adjust this setting unless you have consulted your authorized dealer or technical services. Unauthorized adjustment will result in unsatisfactory performance of this product.



20. Press **button one (1)** once to highlight **WATER SOURCE**.



21. Now press **button three (3)** or **four (4)** key to change **WATER SOURCE** value. For problem water set to **WELL/OTHER**. For clean, city water choose **MUNICIPAL**.



22. Press **button one (1)** once to highlight value.



23. Now press **button three (3)** or **four (4)** to change **REGEN. TIME**.

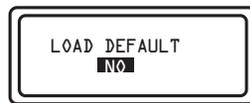

24. Now press **button one (1)** once to highlight **LOAD DEFAULT**. **DO NOT** change this setting.



25. Press **button one (1)** once to **COMPLETE PROGRAMING**.

START-UP INSTRUCTIONS (CONTINUED)

STEP 5. ADD SALT TO BRINE CABINET

Put 80 to 100 lbs [40 kg] of water softener salt into the brine tank. The unit will automatically fill the water to the correct level when it regenerates.

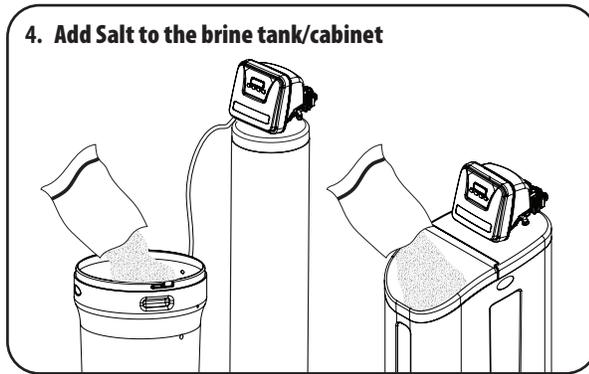
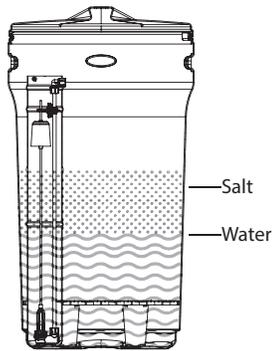

Congratulations!
Start-Up Instructions are now complete – the unit is operational.

PLUMBING SYSTEM CLEAN UP

The following procedures are guidelines only but have proven successful in most instances. Under no circumstances should any procedure outlined below be followed if contrary to any other household appliances manufacturer's instruction(s). Should there be any questions concerning the advisability of performing a procedure, it is strongly recommended that the dealer be consulted prior to performing the procedure. Canature is not liable for any damages that result of failing to follow the household appliance manufacturer's instructions and/or any issues that arise from following those instructions.

WATER HEATER

If the water heater has been exposed to both iron and hardness for a long period of time, replacement of the heater tank maybe the only practical solution to prevent continued staining originating from this source. After completing the installation of the softener, clean the water heater by following these instructions;

1. Turn the energy supply to the water heater OFF and shut the heater inlet water valve OFF.
2. Drain hot water tank completely. OPEN the Inlet Water Valve allowing the heater tank to be refilled with iron free water. Continue flushing until clear water runs to the drain.
3. If, after 30 minutes flushing, the water does NOT clear, terminate flushing operation.
4. REFILL hot water heater with water and pour approximately .5 gal or [.19 Litres] of household bleach into the top of the heater tank. Allow bleach solution to stand in tank for thirty (30) minutes. Flush tank.
5. Turn the energy supply back ON.

DISHWASHER

Dishwashers may have scale buildup due to prolonged exposure to hard water effecting the factory rated performance. Consult the owner's handbook and follow the manufacturer's instructions.

TOILET FLUSH TANKS

To clean up toilet flush tanks:

1. Pour 4 to 6 fluid ounces [120-175 millilitres] of resin mineral cleaner, Pro-Rust Out or any other suitable cleaner that contains a mild acid, such as CLR, into flush tanks and bowls, and let stand for one (1) hour.
2. When installation is completed, flush toilets several times with conditioned water.
3. If stains or deposits return, check that the lines are connected to treated water.

SANITIZATION PROCEDURE

Care is taken at the factory to keep your water conditioner clean and sanitary. Materials used to make the conditioner will not infect or contaminate your water supply, and will not cause bacteria to form or grow. However, during shipping, storage, installing, and operating, bacteria could get into the conditioner. For this reason, sanitizing is suggested when completing installation.

TO SANITIZE:

1. Be sure to complete all installation steps, including programming before sanitizing.
2. For effective and complete sanitization, Sani-System Liquid Sanitizer Concentrate is recommended. Pour one packet into the brine well located in the cabinet or brine tank. Alternatively use 3/4 fl oz [22 ml] of common household bleach.
3. Start an immediate regeneration.
4. The solution in the brine well is drawn into and through the water conditioner to sanitize itself. This sanitizing regeneration takes two (2) hours. Then, treated water is available for your use.

Sanitizing is recommended by the Water Quality Association for disinfecting. Quarterly sanitizing is suggested for low-quality water supplies.

Sani-System Liquid Sanitizer Concentrate



Item #50033 One (1) packet – conditioner sanitizer. 2.5 fl oz [7.4 ml]

SYSTEM MAINTENANCE



Maintenance of your new water softener requires very little time or effort but is essential. Regular maintenance will ensure many years of efficient and trouble-free operation. Check with your local dealer about setting up a regular maintenance plan. Failure to follow maintenance instructions and schedule will result in the unit failing to operate properly and void your warranty.

CARE OF YOUR SOFTENER

To retain the attractive appearance of your new water softener, occasionally clean it with a mild soap solution. Do NOT use abrasive cleaners, ammonia, or solvents.

SERVICE SCHEDULE

- The seals and spacers along with the piston assembly should be inspected/cleaned or replaced annually or as required depending on the inlet water quality and water usage. See Inspection and Replacement of Piston Assembly and Seal and Spacer Kit.
- The injectors should be cleaned/inspected or replaced annually or as required depending on the water quality and use. See Clean Injector Assembly.
- Your inlet water quality and water consumption will determine how often the media should be replenished or replaced. Check with your water treatment expert for the media bed change frequency.
- Maintenance materials – Please see Common Spare Parts.

SYSTEM MAINTENANCE (CONTINUED)

ADDING SALT TO THE BRINE TANK / CABINET

Use only clean salt labeled for water softener use, such as crystal, pellet, nugget, or button. The use of natural rock salt is discouraged because it contains insoluble silt and sand which buildup in the brine tank and cause problems with the system's operation.

- Put 40 kg [80 to 100 lbs] of water softener salt into the brine tank.
- Add the salt directly to the tank, filling it no higher than the top of the brine well. Do NOT overfill the salt tank as the additional weight of salt adds to the potential for salt bridging due to compaction.
- Check the salt level regularly. Remove the lid from the cabinet or brine tank. Ensure that the salt level is above the brine water level.

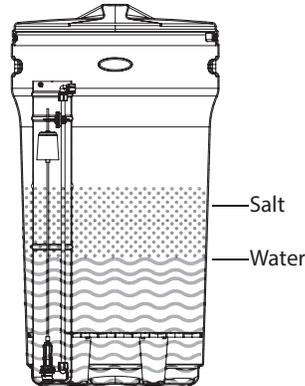
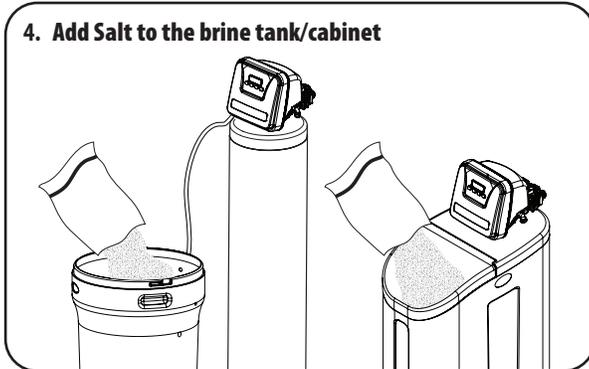

NOTE

The salt level should always be above the water level.

SALT BRIDGING

Humidity or poor-quality salt may create a cavity between the water and the salt. This action, known as 'bridging', prevents the brine solution from being made, and prevents your water from being conditioned.

If you suspect salt bridging because of a lack of soft water or salt is NOT being consumed, use a rubber mallet to pound on the outside of the plastic brine tank or pour some warm water around the inside edges of the salt tank to break up the bridging. Allow four (4) hours to produce a brine solution, then manually regenerate the softener. This should always be followed by allowing the unit to use up any remaining salt and then thoroughly cleaning out the brine tank.

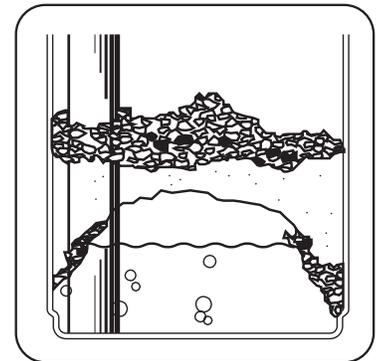

CLEANING OF YOUR BRINE OR SALT TANK

Salt tanks will build up sludge (undissolved salt) in the bottom that increases over time. Every 2 – 3 years the salt tank(s) should be cleaned out and restarted using the original start-up instructions.



CAUTION

Liquid brine will irritate eyes, skin, and open wounds. Gently wash the exposed area with fresh water. Keep children away from your water softener.

NOTICE

Incorrect start-up, water above the salt level – not enough salt in tank – will affect the unit's capacity and result in hardness slippage. Should either of these situations happen, or the unit fails to regenerate for any other reason, correct the problem first, then regenerate the unit manually. Regenerate two times in a row to restore the reserve capacity and bring the media bed back up to specification.

SYSTEM MAINTENANCE (CONTINUED)

AUTOMATIC RESIN CLEANER SOLUTION EASY FEEDER INSTALLATION

Optional ResCare Easy Feeders are devices that attach to your brine tank and automatically dispense the ResCare cleaner into the brine solution where it cleans the resin during the regeneration cycle.

The Easy Feeder hooks onto the inside of your brine tank and feeds the cleaning solution into your brine well. You **MUST** maintain the level of cleaner in the Easy Feeder for proper operation. A ResCare Easy Feeder is essential if your raw water contains measurable amounts of Iron.

RESCARE® EASY FEEDER INSTALLATION INSTRUCTIONS ROUND BRINE TANK

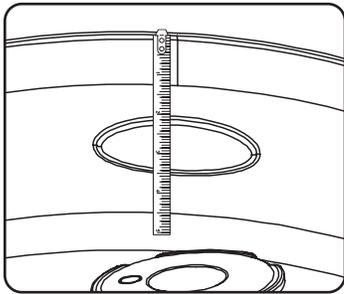

1. Measure 2 inches from the top of the tank beside the oblong molding.

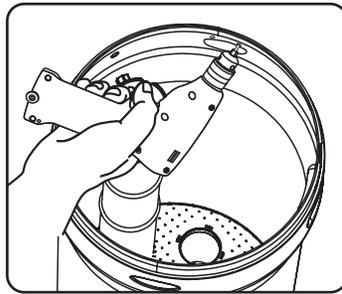

2. Mark the location of the holder and drill.

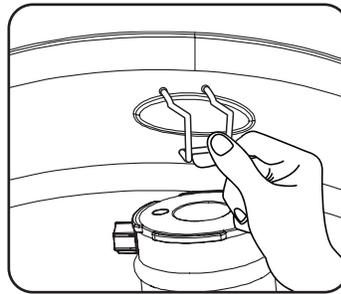

3. Install the holder.

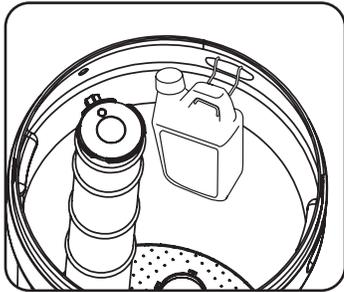

4. Hang the ResCare bottle on the hanger.

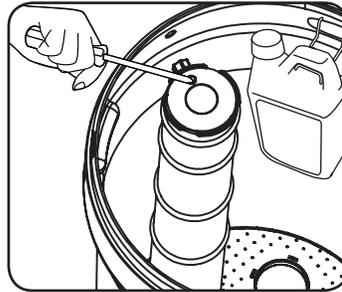

5. Take off the small hole cover on the Brine Well lid.

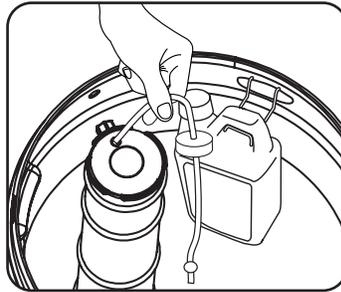

6. Take off the cover of the ResCare bottle. Insert the wick, making sure it touches the bottom of the bottle. Insert the other end of the tube completely into the hole in the brine well cap. Automatic feeding will start in a few hours.

RESCARE® EASY FEEDER INSTALLATION INSTRUCTIONS SQUARE BRINE TANK

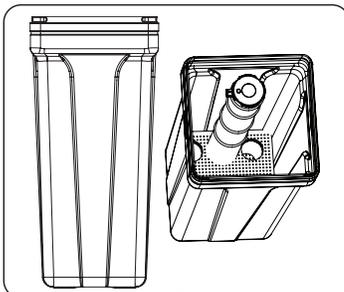

1. Install the grid and brine well inside the square tank.

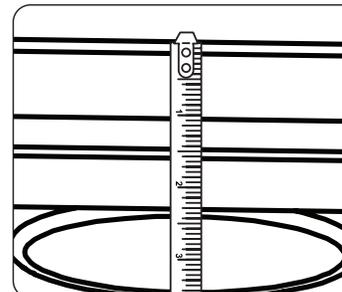

2. Measure 2 inches from the top of the tank beside the oblong molding.

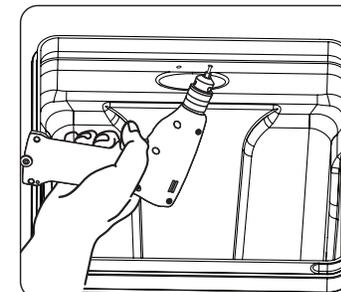

3. Mark the location of the holder and drill.

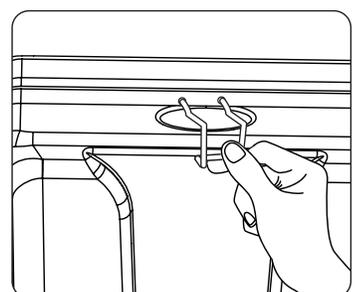

4. Install the holder and the ResCare bottle.

RESCARE® EASY FEEDER INSTALLATION INSTRUCTIONS SQUARE BRINE TANK - CONTINUED

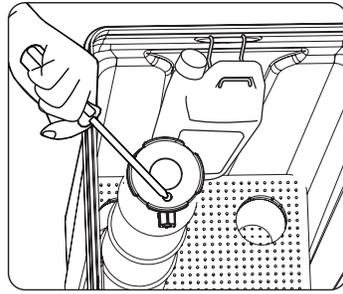
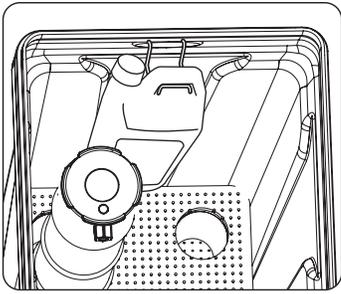

5. Take off the small hole cover on the brine well lid.

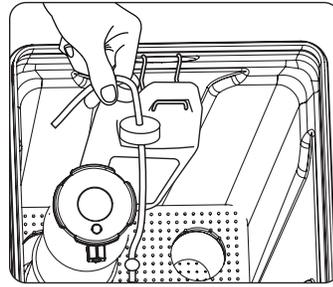

6. Take off the cover of the ResCare bottle. Insert the wick, making sure it touches the bottom of the bottle. Insert the other end of the tube completely into the hole in the brine well cap. Automatic feeding will start in a few hours.

RESIN CLEANER

An approved resin cleaner **MUST** be used on a monthly basis if your water supply contains iron. The amount of resin cleaner and frequency of use is determined by the quantity of iron in your water. Consult your dealer and follow the directions on the resin cleaner package.



Item #	Description
45127	Rust Out - 5 lb. Bottle
45128	Rust Out - 50 lb Pail (USA only)



Item #	Description
55030005	Easy Feeder - 0.5 oz/day Feeder
55030006	Easy Feeder - 1.0 oz/day Feeder
55030007	Easy Feeder Starter Kit ½ oz with 64 oz ResCare



Item #	Description
45147	ResCare - 1 gal. (128 oz) Bottle
80030022	ResCare - 64 oz Bottle (Easy Feeder Refill)

SERVICING YOUR CONTROL VALVE

BEFORE SERVICING, YOU WILL NEED TO:

1. Shut the water supply to the softener OFF, put the softener into the BYPASS position.
2. Relieve water pressure in the softener by stepping the control into the backwash momentarily.
3. Return the control to the SERVICE position.
4. Unplug the electrical cord.
5. Disconnect the drain line connection.

Always follow these steps prior to servicing the valve.



CAUTION

RISK OF FLOOD
Disassembly while under pressure can result in flooding.



WARNING

RISK OF SHOCK
Unplug the unit before removing the cover or accessing any internal control parts.

SERVICING YOUR CONTROL VALVE (CONTINUED)

POWERHEAD REMOVAL

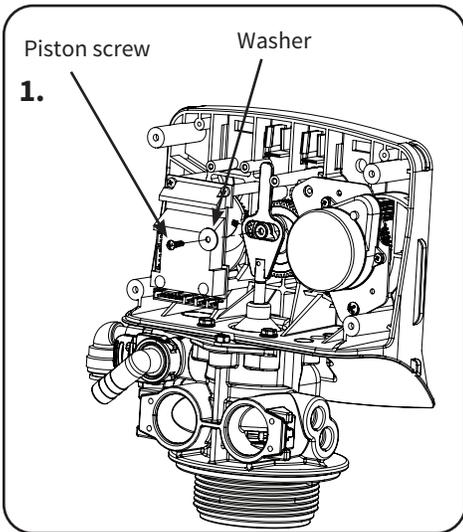

To remove the powerhead:

1. Remove screw & washer from piston rod link.

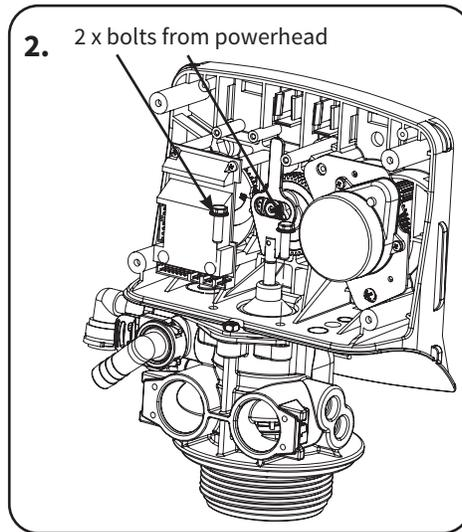

2. Remove two (2) bolts securing powerhead to body.

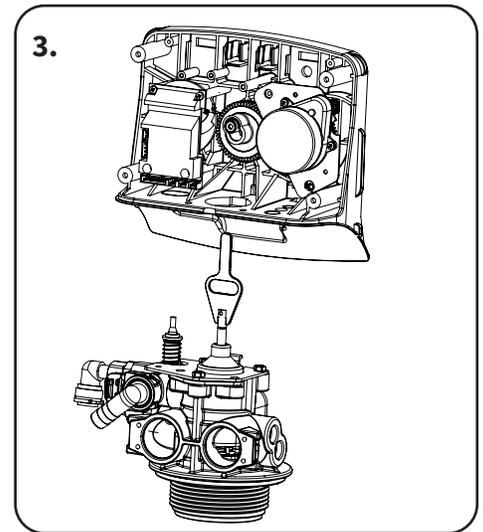

3. Remove powerhead from body.

INSPECTION & REPLACEMENT OF PISTON ASSEMBLY AND SEAL & SPACER KIT

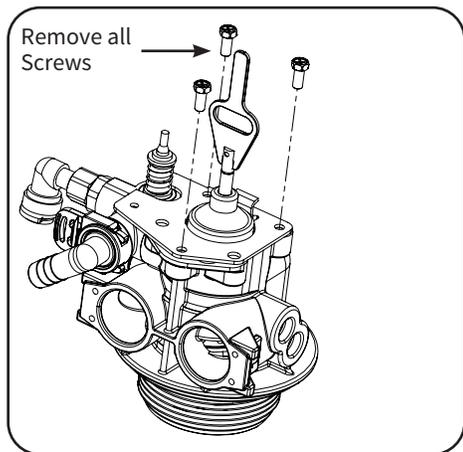

1. Follow steps 1 to 3 of Powerhead Removal above.

2. Remove three (3) screws from the plate on the valve body.

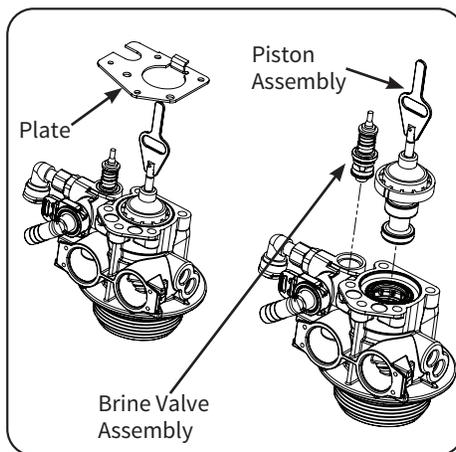

3. Remove the plate from the valve body and pull the piston assembly from the valve. The brine valve assembly can also be removed in this stage.

4. If only lubricating, remove the piston assembly, grease it with silicone lubricant (Part #92360) and put back in.

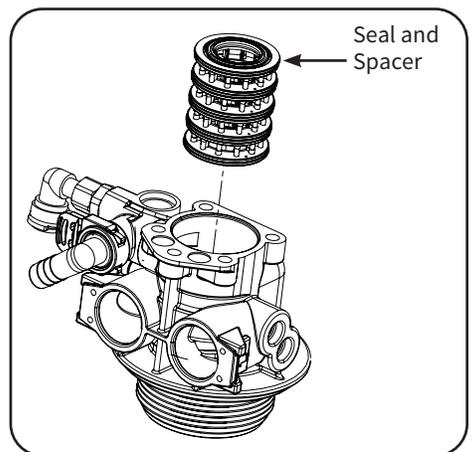

5. Replace seal and spacer set as shown. Place spacer in then a seal and repeat until finishing with a seal. Important, use the specialized end spacer and note it's placement.

6. Lubricate the piston assembly with silicone lubricant (Part #92360) and then replace the Piston Assembly.

NOTICE

Do NOT use petroleum-based grease products during replacement and assembly.

SERVICING YOUR CONTROL VALVE (CONTINUED)

CLEAN INJECTOR ASSEMBLY

Sediment, salt, and silt will restrict or clog the injector. A clean water supply and pure salt will prevent this from happening. The injector assembly is located on the right side of the control valve when facing your softener.

The assembly is easy to clean, start by:

1. Shut the water supply to your softener OFF.
2. Reduce the pressure by opening a cold-treated tap.
3. Using a screwdriver, remove the two (2) screws holding the injector cover to the control valve body.
4. Carefully, remove the cover, and disassemble as shown below.
5. The injector orifice is removed from the valve body by carefully turning it out with a screwdriver.
6. Remove the injector throat the same way.
7. Carefully flush all parts including the screen.
8. Use a mild acid such as vinegar or Pro Rust Out to clean the small holes in the orifice and throat.
9. Reassemble by reversing the procedure.

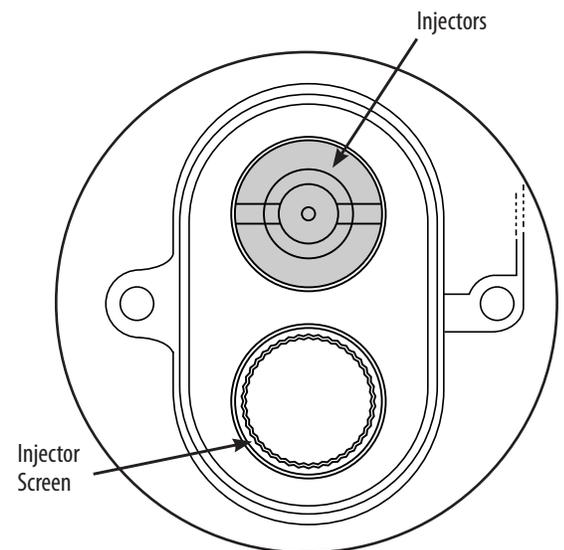
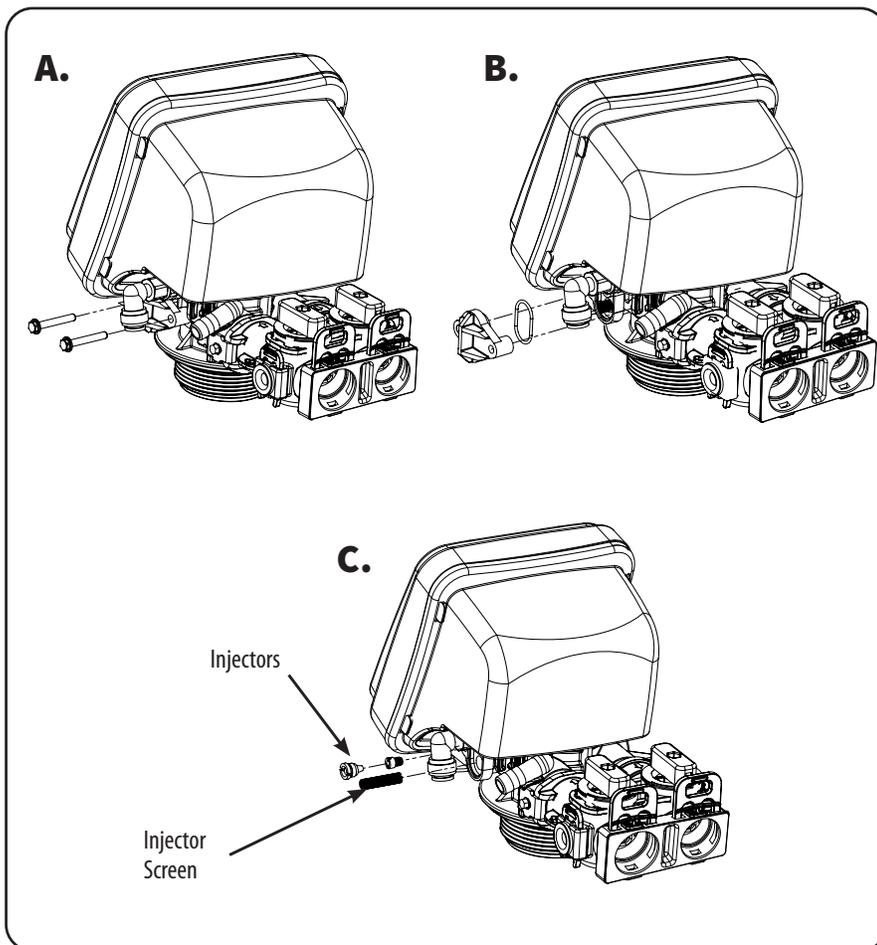

- A.** Remove the two (2) screws of the injector cap.
- B.** Pull the Injector Cap out.
Remove the Injector Assembly, O-ring, and screen.
- C.** Clean the injectors and replace the cap.
 - Be sure to replace the O-rings when reassembling and lubricate with approved 100% silicone-based lubricant. Order Part #92360.

TROUBLESHOOTING GUIDE

NOTE

Before attempting any troubleshooting, be sure to test the water. The tests should include;

1. Raw water
2. Hot treated water
3. Cold treated water.

PROBLEM

DELIVERS UNTREATED WATER

The bypass is closed, sending raw water past the unit.	Return the bypass valve to the open position to service the home. See Manual Bypass.
Bypass loop in the home's plumbing.	Close outlet valve only on softener bypass, open nearest softened water line. If no water flows, then there is not a bypass in the plumbing. If there is water flow, then there is a hidden bypass in the plumbing and you need to call the installer.
No salt or low salt level.	Fill salt above the water line in the salt tank. Low salt will affect the softener's capacity. See adding salt to the brine tank.
Not programmed correctly for the current application.	Verify programming is set correctly for the current application. Verify programming is set to correct the hardness level and the number of people living in the home. See Start-Up & Programming.

EXCESSIVE WATER IN THE SALT TANK

Refer to maintenance section.	Clean the injectors and the salt tank.
-------------------------------	--

NOT GENERATING AUTOMATICALLY, NOT METERING FLOW

Check diagnostics for last regeneration.	Open nearest softened water outlet and check if gallons are counting down on meter. If not metering, contact your authorized installer.
--	---

NOT USING SALT

Injectors or injector screen plugged. Refer to maintenance section.	Clean and or replace injectors and screens. See salt bridged in the salt tank.
---	--

NOT REGENERATING AUTOMATICALLY CAUSING ALARMS

Caused by a power outage or brownout during regeneration.	Unplug power for 30 seconds then reconnect. If the alarm continues contact your authorized installer.
---	---

UNIT REGENERATES BUT DOES NOT USE SALT

Drain line flow control is plugged.	Clean or replace injectors. Clean drain line flow control to ensure there are NO kinks or restrictions in the drain line.
-------------------------------------	---

USING MORE SALT THAN EXPECTED

Is the unit set properly for salt efficiency, is the programming correct for hardness and number of people?	Check programming. Is the unit set properly for salt efficiency, is the programming correct for hardness and number of people?
---	--

ALARMS AFTER REGENERATION

Caused by a power outage or brownout during regeneration.	Unplug power for thirty seconds then reconnect. If the alarm continues, contact your authorized installer.
Corroded or damaged rear circuit.	Contact authorized installer and replace circuit.

DISCOLORED WATER

Check with your local water authority to see if there if there has seen water main activity in your area.	If there has been, manually regenerate the unit a couple of times in a row to clear the color. If there hasn't been and main activity, contact your authorized installer.
Iron bleed through. If there are small amounts of iron in your raw water supply it will eventually build up in the resin and cause bleed through.	See settings to compensate for iron in the water. If required add-on an automatic resin feeder. Contact your authorized installer or local plumbing store to purchase an approved resin cleaner.

TROUBLESHOOTING GUIDE (CONTINUED)

PROBLEM	
EXCESSIVE PRESSURE LOSS	
Peak or continuous service flow rate may be exceeding capacity causing the unit to be restrictive due to size.	<ol style="list-style-type: none"> 1. Check unit specifications to ensure proper sizing for the application. 2. Degradation of resin due to chlorine or chloramine. <ul style="list-style-type: none"> • Replace the resin bed.
HALL SENSOR - ERROR CODE	
Power surge	Unit is in normal home position showing 'Hall Sensor Error'. <ol style="list-style-type: none"> 1. Unplug for one (1) minute. 2. Plugin. 3. Initiate Manual Regen if the error reoccurs .
Circuit failure	Transformer or motor failure – unit will NOT be in the home position; water may be running at the drain. Contact your authorized installer for parts and or assistance.
Motor failure	Replace the motor and transformer if unable to determine the output of the transformer separately.

COMMON SPARE PARTS

Part Number	Description
60090003	QC Valve connector one (1) inch straight with O-ring
60090006	QC Valve connector three-quarters (3/4) inch straight with O-ring
60090010	QC Valve connector three-quarters (3/4) inch elbow with O-ring
60010025	Locking clip large
60010069	Locking clip small
60010006	Bypass tool
60010052	Transformer 12 volt
60010382	Problem water injector kit
92360	100% silicone-based lubricant
50033	Sani-System liquid concentrate – 1 packet
99003	Media Funnel
80050083	HACH Water Hardness Test Strips 50 per bottle

WARRANTY

565 Residential Water Softener

NOTICE: THIS MANUAL CONTAINS A LIMITED WARRANTY. BY INSTALLING AND/OR USING THIS PRODUCT, YOU WAIVE CERTAIN LEGAL RIGHTS INCLUDING THE RIGHT TO SUE OR CLAIM COMPENSATION IN THE EVENT OF PROPERTY DAMAGE, INJURY AND/OR DEATH.

Products manufactured and assembled by Canature WaterGroup™ are warranted to do the work for which they are intended where properly installed, operated and maintained. Canature WaterGroup™ warrants each new residential water filter to be free from defects in materials and workmanship subject to the qualifications or exclusions below.

Residential Systems are defined by pressure tank size and / or the amount of resin or filter media contained in the tank. Residential systems use up to 13" [330 mm] diameter tanks and can contain up to 3.0 cubic feet [28.3 L] of resin or filter media.

Warranty on Control Valve and Parts:

Canature WaterGroup™ will replace or repair any part (except for Wear and Tear Items – Media, Piston, Seals and Brine Valve) which fails within seven (7) years from date of manufacture, as indicated by the serial number, provided the failure is due to a defect in material or workmanship. The only exception from the date of manufacture shall be proof of purchase or installation is provided and then the warranty period shall be from the date thereof.

Warranty on Mineral Tanks and Brine Tanks:

Canature WaterGroup™ will provide a replacement mineral tank or brine tank to any original equipment purchaser in possession of a tank that fails within the lifetime of the original owner, provided the failure is due to a defect in material or workmanship and that the water filter or filter is at all times operated in accordance with specifications provided in the Owner's Manual and not subject to freezing or vacuum.

Exclusions:

Damage to any part of this water filter or filter as a result of misuse, misapplication, neglect, alteration, accident, installation or operation contrary to our printed instructions, damage to ion exchange resin and seals caused by chlorine / chloramines in the water supply, damage to internal pistons and seals caused by wear and tear from iron, manganese, sediment and or silt, or damage caused by any force of nature is not covered in this warranty. At our sole discretion, we will repair or replace defective parts if our warranty department determines it to be defective under the terms of this warranty. Canature WaterGroup™ assumes no responsibility for consequential damage, labor or expense incurred as a result of a defect or failure. Media and Resin coverage is limited to the warranty provided by the original manufacturer.

As a manufacturer, we do not know the characteristics of your water supply. The quality of water supplies may vary seasonably or over a period of time. Your water usage may vary as well. Water characteristics can also change if the appliance is moved to a new location. For these reasons, we assume no liability for the determination of the proper equipment necessary to meet your requirements, and we do not authorize others to assume such obligation for us. Further, we assume no liability and extend no warranties, express or implied, for the use of this product with a non-potable water source or a water source which does not meet the conditions for use as described in the Owners Guide.

CANATURE WATERGROUP'S™ OBLIGATIONS UNDER THIS WARRANTY ARE LIMITED TO THE REPAIR OR REPLACEMENT OF THE FAILED PARTS OF THE WATER SOFTENING SYSTEM AND WE ASSUME NO LIABILITY WHATSOEVER FOR DIRECT, INDIRECT, INCIDENTAL, CONSEQUENTIAL, SPECIAL, GENERAL OR OTHER DAMAGES.

Return of Goods:

An authorization number must be obtained before returning any merchandise. NOTE: All material returned to Canature Watergroup must be returned freight prepaid. Upon inspection, if our warranty department determines the goods to be defective under the terms of this warranty, the warranty shall be limited to the defective parts to be repaired, replaced, or credited at Canature WaterGroup's discretion. You pay only freight to return defective parts to our factory and local dealer charges, including but not limited to labor charges, travel and transportation expenses, and handling fees.

Some State & Provincial jurisdictions do not allow limitations on how long an implied warranty lasts, so the above limitation may not apply to you. Similarly, some State & Provincial jurisdictions do not allow exclusion of incidental or consequential damages, so the above limitations or exclusions may not apply to you. This warranty gives you specific legal rights, and you may also have other rights, which vary from jurisdiction to jurisdiction. Consult your authorized Dealer for warranty and service information.

Toll Free: 1-877-288-9888
www.canaturewg.com