

89 Softener Quick Start Manual

STEP 1 – INSTALLATION STEPS

Determine the best location for your water Softener, bearing in mind the location of your water supply lines, drain line and 120 volt AC electrical outlet. Subjecting the Softener to freezing or temperatures above 43°C (110°F) will void the warranty.

Please notice the inlet and outlet labels on the valve as shown here to determine the position of the equipment:

For UF Softener - The inlet should be on the right hand side of the valve and out on the left hand side

For DF Softener - The inlet should be on the left hand side of the valve and out on the right hand side

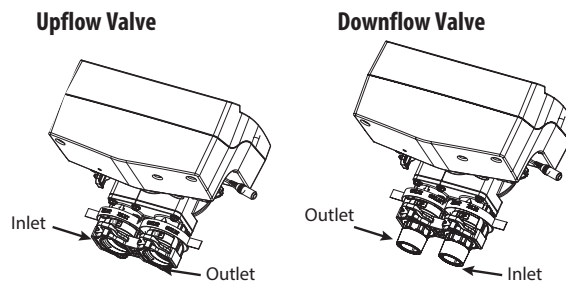

STEP 2 – PREPARATIONS

1. Media Installation

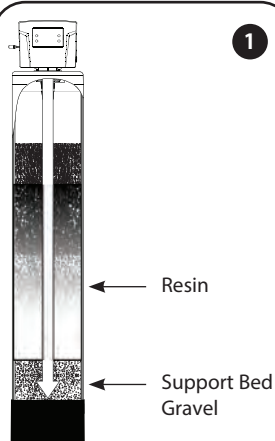

1. Fill tank one quarter full of water to protect distribution during gravel installation.

Place the media into the tank in the order indicated above. Slowly and carefully add the gravel support bed and the filtration media leveling each layer as it is placed into the tank.

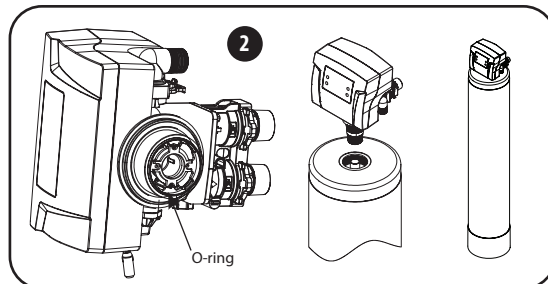

2. Unplug the riser tube, carefully position the valve over it and turn the valve into the threads in the fiberglass tank, tightening securely into tank. Note: Ensure that the internal O-ring in the valve fits securely over the riser tube. Silicone grease (part # 92360) or other food grade lubricant may be applied to the O-ring to ease installation of the riser tube.

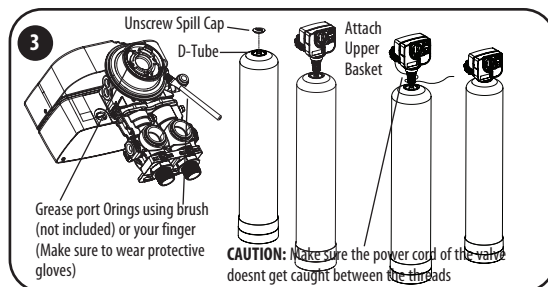

3. Lube the bottom Valve Orings with the grease supplied, Attach the Upper Basket. Unscrew the spill cap. Carefully Slide the D-Tube inside the Valve and Screw the Valve inside the Tank such that the power cord doesn't get caught between the valve and the tank.

STEP 3 – ATTACHING BYPASS TO VALVE

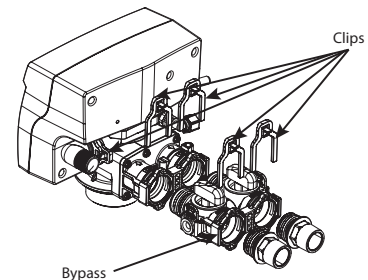

Make sure the bypass is attached well to the control valve. Connect the elbow connectors to the bypass with red clips. Connect the inlet and outlet of the water Softener to the plumbing of the house. The control valve must not be submitted to temperatures above 43°C (110°F). When sweat fittings are used, to avoid damaging the control valve, solder the threaded copper adapters to the copper pipe and then, using Teflon tape, screw the assembly into the bypass valve.

Do not use pipe thread compound as it may attack the material in the valve body.

STEP 5 – ASSEMBLING BRINE TANK

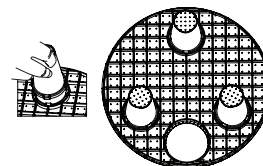

a) Attach the three brine grid legs to grid plate. The legs will snap on to the tabs of the salt plate making a "click" sound. For square brine tank there are four legs.)

b) Insert the brine well assembly inside the grid plate

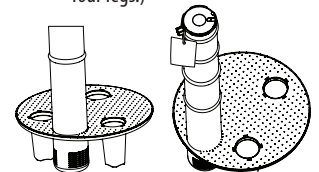

c) Drop the brine grid with brine well inside the brine tank such that the nut fitting faces the hole on the brine tank. Then press the grid evenly inside the brine tank until the brine grid legs touches the bottom of the brine tank.

IMPORTANT: IN ROUND BRINE TANK, IT IS IMPORTANT TO ALIGN THE HANDLE TO THE BRINE WELL AS SHOWN

The hole in the brine tank should line up with the brine line as shown for round and square brine tank.

STEP 4 – DRAIN LINE CONNECTION

Using Teflon tape, screw the 1/2" hose barb and attach oring into the drain port in the valve. Attach 1/2" drain hose (Supplied with some models and brands) to the hose barb and tighten securely with a hose clamp (Supplied with some models and brands).

Run the drain line to a floor drain or a laundry drain. Complete any necessary plumbing.

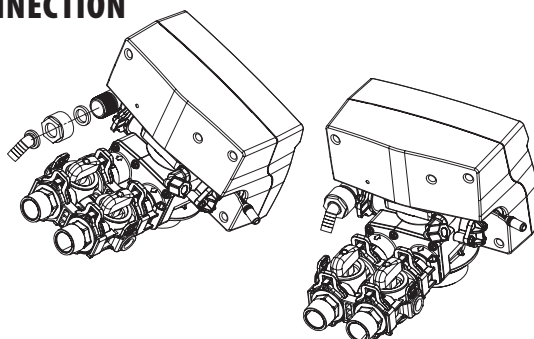

STEP 5 – ASSEMBLING BRINE TANK CONTINUED

d) Take the brine tube and insert the nut and plastic sleeve as shown below.

Insert Sleeve

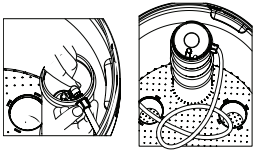

e) Insert the tube in the float assembly elbow and hand tighten the nut. In many cases the brine line already come installed from the factory. Leave the other end of the brine line tube inside the brine tank

f) For installation of brine tank at the installation site, pull the other end of the brine tube from the hole on the brine tank. The completed assembly is shown on right.

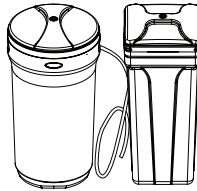

STEP 6. ATTACHING BRINE TUBING TO THE BRINE LINE OF THE VALVE

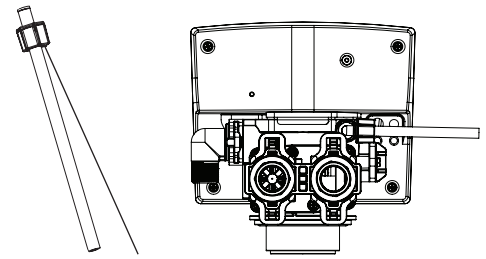

Insert Sleeve inside the Tubing

The new versions of 89 Valve have Quick Connect Brine Fitting

STEP 7 – CONNECT SOFTENER TO THE HOUSE PLUMBING

Any solder joints near the valve must be done before connecting any piping to the valve. Always leave at least 6" (152 mm) between the valve and joints when soldering pipes that are connected to the valve. Failure to do this could cause damage to the valve.

Upflow Water Softener Installation

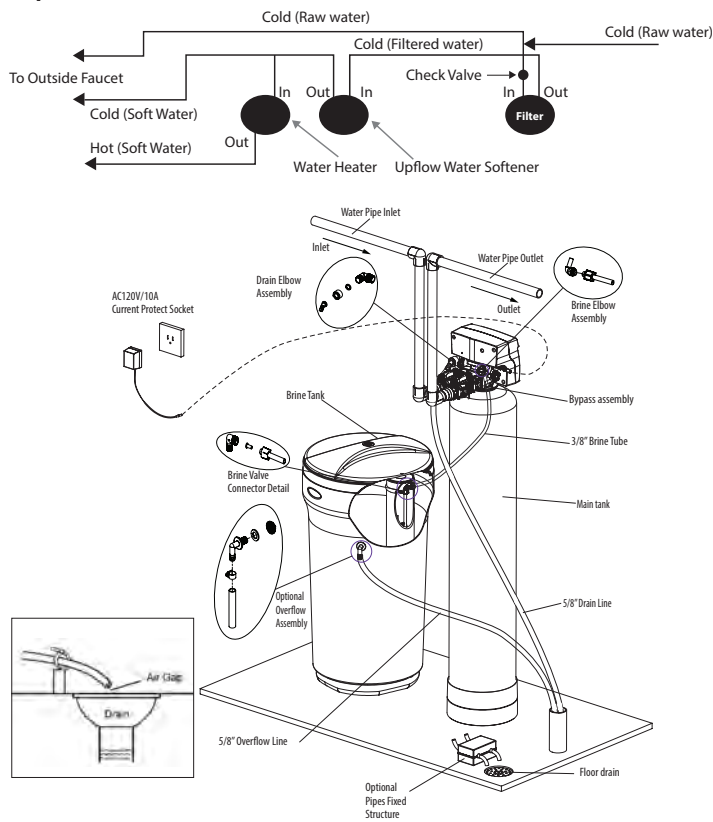

Downflow Water Softener Installation

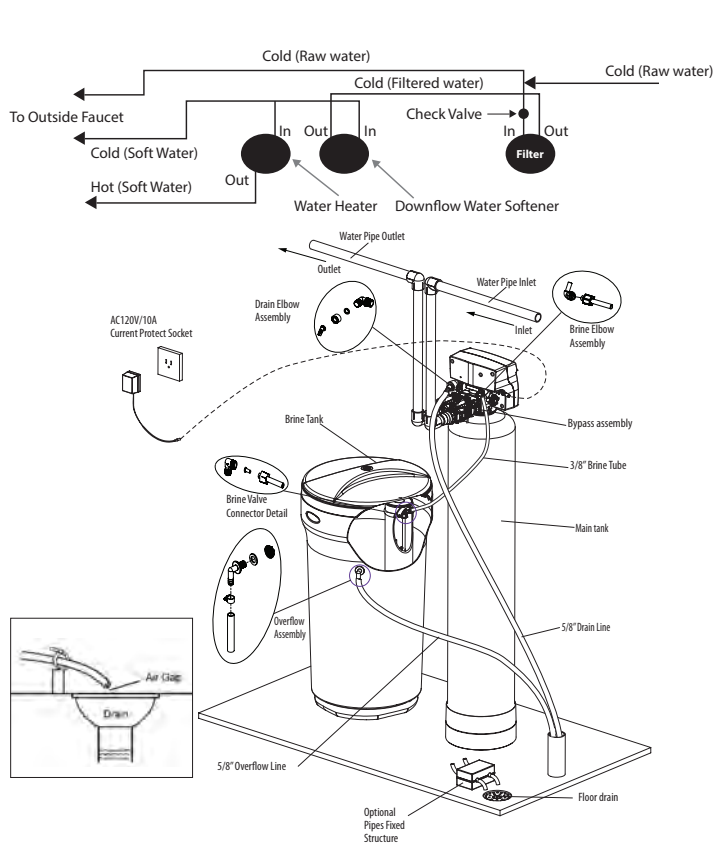

STEP 8 – START UP INSTRUCTIONS

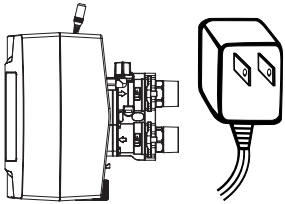

1. Connect the transformer to the valve. Plug the 12-volt transformer into a 120 VAC 60 Hz outlet.

2. Open the brine tank/cabinet salt lid and add water until there is approximately 3" (75 mm) of water in the tank. Do not add salt to the brine tank at this time.

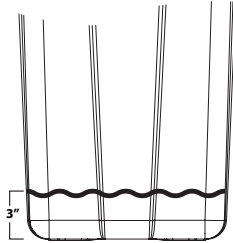

Key Pad Configuration:



MENU

This function is to enter the basic set up information required at the time of installation.



SET

This function is to accept the values if changed and advance to the next page in the menu.



+



-

These buttons are used to increase or decrease the value of the settings while in the programming mode.

Familiarize with Button Configuration:



MENU

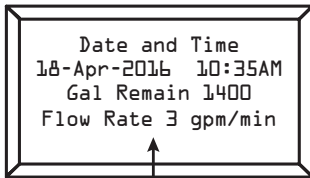

+



SET



-

The controller will show the following on the screen - Time, Date and Gallons Remaining for Regeneration

3. When power is supplied to the control, the screen will display "INITIALIZING WAIT PLEASE" while it finds the service position.

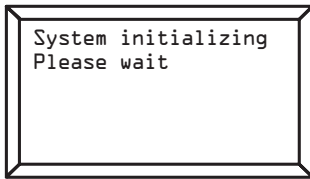

4. Manually regenerate the valve. If screen is locked, press Menu Key for 5 seconds to unlock.

Manual Regeneration

Manually Regenerate the Valve and move it to backwash position. Press Menu Key



and Scroll down using Up and Down Arrow buttons to "Manual Regen".

Press "SET" Select "Regen Now"

SERVICE

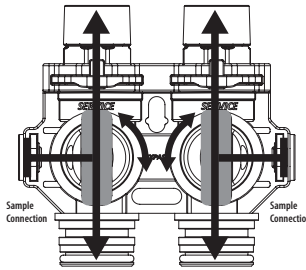

BYPASS

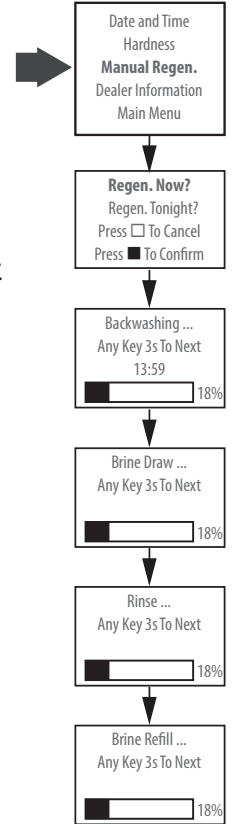
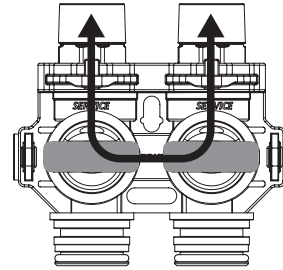

5. Please set up date and time of day and hardness. The Valve is already programmed from factory for Softener Models.

Set Up Current Time of Day and Regeneration Time When Softener Should Regenerate When No one uses Water in House.

Press Menu Key and Select "Date and Time" using "Set" button and set for setting the regeneration time, Press Menu Key and Select Main Menu till you hear a beep and select Regen time

6. Add Salt to the brine tank/cabinet Put 40 kgs of crystal water softener salt in the brine tank. The unit will automatically fill the water to the correct level when it regenerates.

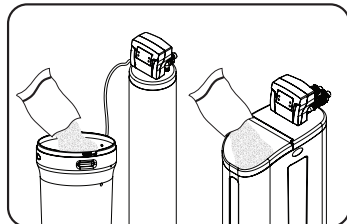

Set up Current Time of the Day and hardness:

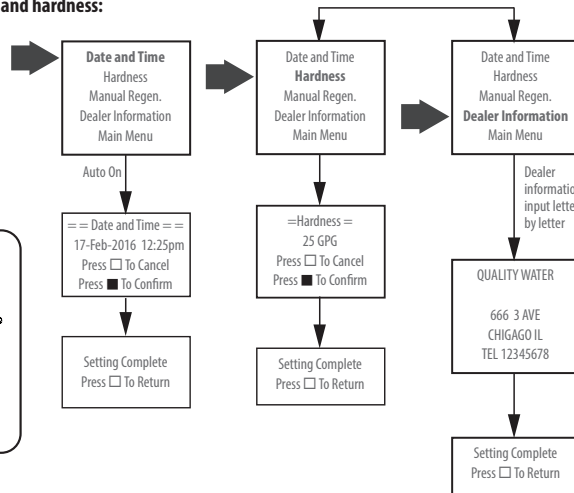

Set up Regeneration Time:

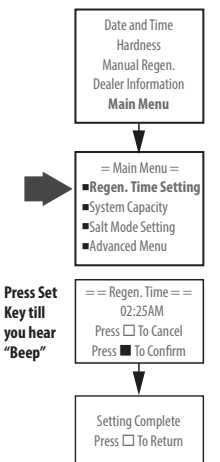

Press Set Key till you hear "Beep"

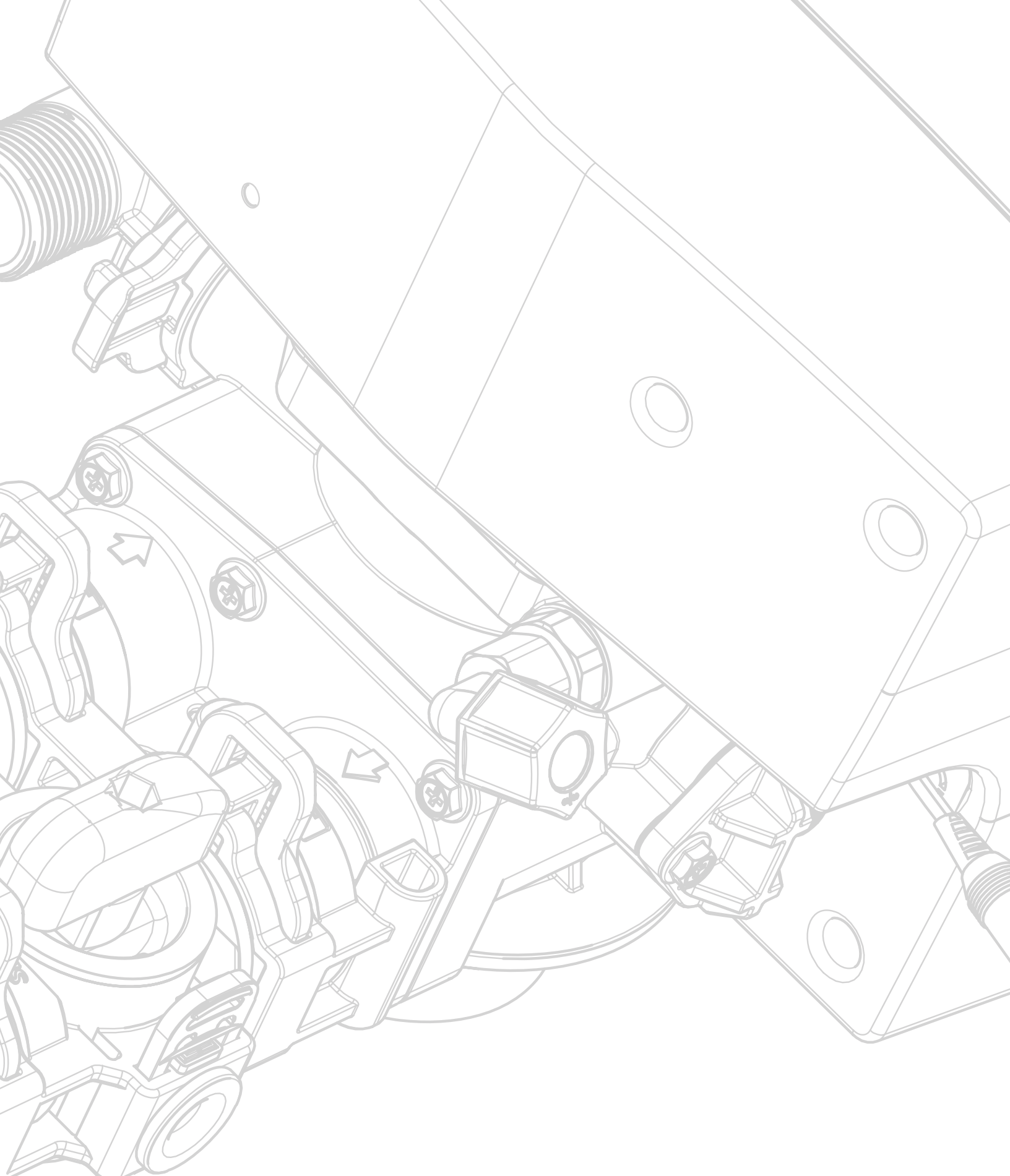

TOLL-FREE: 1-877-288-9888

Regina, SK • Cambridge, ON • Whitestown, IN
Phoenix, AZ • Houston, TX • Guadalajara, MX

**Follow the Instruction Manual to Complete
the Installation of the Product**

55244 2023-10-18