

Res-Up[®] Feeder Installation Instructions

1. Remove top cover, fill the Res-Up[®] Feeder (plastic container) to the top with water so that the wick retaining clip, tube and wick are wetted, allow to soak for 15 minutes or more.
2. Empty water and pull tube and wick through Feeder until slack is removed from inside. The outlet end tube and wick must be below the bottom level of the Res-Up[®] Feeder.
3. Drill two 1/4" holes in brine tank as shown in Figure 2.
4. Drill a 5/8" hole in the brine well cap as shown in Figure 3.
5. Clip mounting bracket over feeder with "hooks" pointed up. Insert end of tube in the brine well cap and mounting bracket with the 1/4" holes in the brine tank, rotating feeder downward into position as shown in Figure 1.
6. Fill Feeder with Res-Up[®] Cleaner to "Fill Line" on label.
7. Release cover on Feeder and automatic feeding will occur in a few hours.

Figure 1

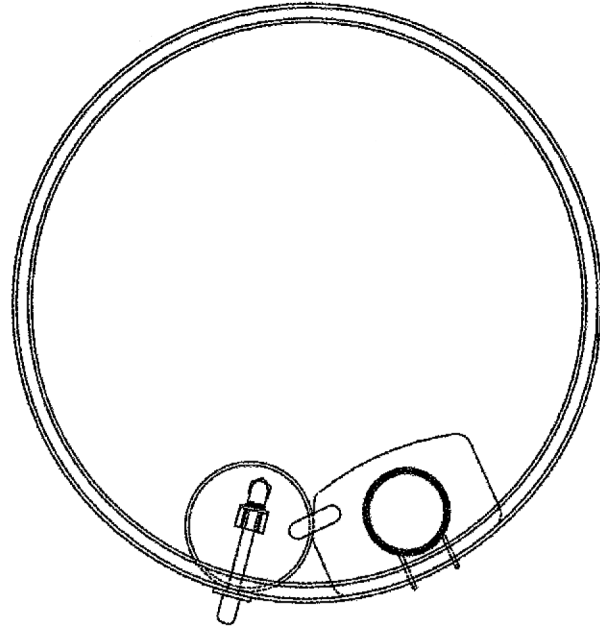

Figure 2

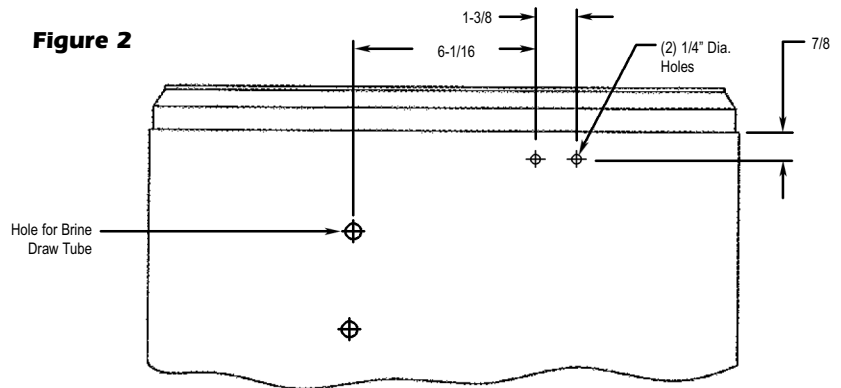

Figure 3

