



5600SXT Valve

Iron & Sulfur Filter Operation Manual

Performance and Specifications

Hydrotech Iron & Sulfur (Manganese Greensand) Filter

Item Number	Model Number	Media cu. ft. (litres)	Pipe Size inches (mm)	Max. Bed Capacity (ppm)	Iron removal Capacity (ppm)	Service Flow Rate	Peak Flow Rate	Backwash Flow Rate	Mineral Tank size inches (mm)	KMnO ₄ Regeneration (oz)	Shipping Weight Lbs. (kg)
						USGPM (LPM)					
7621	5600SXTM-8471F	0.75 (21)	3/4 (19)	6000	4500	3.0 (7.6)	4.0 (15)	3.5 (13)	8 x 47 (203 x 1194)	2	120 (55)
7622	5600SXTM-9481F	1.00 (28)	3/4 (19)	8000	6000	3.0 (11)	5.0 (19)	4.0 (15)	9 x 48 (229 x 1219)	4	135 (61)
7623	5600SXTM-10541F	1.50 (42)	3/4 (19)	12000	9000	5.0 (19)	8.0 (30)	5.0 (19)	10 x 54 (254 x 1372)	6	185 (84)

Caution: These water conditioners are not intended to be used for treating water that is microbiologically unsafe or of unknown quality without adequate disinfection before or after the system.

Notes:

Operating Temperature Range: 34° to 110°F (1° to 43°C)

Operating Pressure Range: 20 to 120psi (137 to 827 kPa)

Electrical: 24V/60Hz with a supplied 120V/60Hz Wall Mount CSA Approved Transformer

1. The manufacturer reserves the right to make product improvements which deviate from the specifications and descriptions stated herein without obligation to change previously manufactured products or to note the change.
2. Peak flow rates are intended for intermittent use only and are for residential application only.
3. KMnO₄ refers to Potassium Permanganate.

How Your 5600SXT Water Filter Works

Your automatic iron filter is an ingeniously simple and reliable design. The unit consists of a bed of filter media contained in a fiberglass tank; a specially designed feeder containing potassium permanganate for the regeneration of the filter and a proven automatic control.

Raw water enters your home through the main supply line, enters your iron filter and passes down through the filter media. Any iron, manganese or hydrogen sulfide present in your water supply is exposed to oxygen stored in the filter media. The oxygen causes precipitation of the minerals and they are trapped in the filter media. Only clean filtered water flows to your household water line. The filter media is periodically regenerated, automatically backwashing the trapped minerals to the drain and replacing the oxygen. This is done by introducing potassium permanganate to the media.

1. Your automatic iron filter can be programmed to operate according to your needs by making the appropriate settings on the timer. On the days your filter regenerates, the operating cycles will be automatically performed. In the service position, filtered water is supplied for household use.
2. The automatic control reverses the flow of the water through the filter, backwashing minerals trapped in the filter to the drain.
3. The control pulls a vacuum on the feeder. This causes an exact volume of saturated potassium permanganate solution to be drawn into the filter tank.
4. The control slowly rinses the chemical through the media tank. The potassium permanganate supplies oxygen to the filter media.
5. The control fast rinses the media bed to settle it and to ensure that all the chemical and mineral precipitate is removed.
6. The control adds water to entirely fill the previously evacuated feeder. The feeder is now ready for the next regeneration. The control puts the system into service, supplying iron-free water to the household. All this is performed automatically over a period of 2 ¾ hours. Water runs to the drain for approximately 80 minutes.

In normal operation, the Time of Day display will alternate being viewed with the Volume Remaining display. This display will be in gallons, liters or cubic meters. As treated water is used, the Volume Remaining display will count down from a maximum value to zero or (---). Once this occurs, a regeneration cycle will be initiated at the Set Regeneration Time. Water flow through the valve is indicated by the Flow Indicator that will flash in direct relationship to flow rate.

Example 833 Gallons of Treated Water Remaining

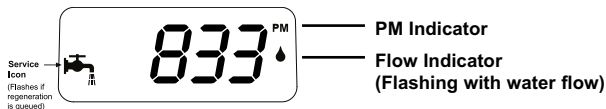

0 Gallons of Treated Water Remaining

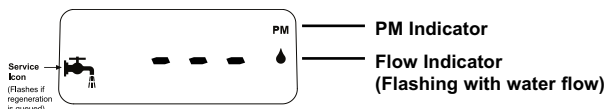

Control Operation During Regeneration

In regeneration, the control will display a special regeneration display. In this display, the control will show the current regeneration step number the valve is advancing to or has reached and the time remaining in that step. The step number displayed will flash until the valve has completed driving into this regeneration step position. Once all regeneration steps have been completed, the valve will return to Service and resume normal operation.

Example Less than 6 minutes
 remaining in Regen
 Step Rapid Rinse

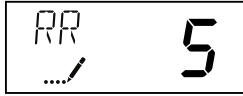

Pushing the Extra Cycle Button during a regeneration cycle will immediately advance the valve to the next cycle step position and resume normal step timing.

Control Operation During Programming

The control will only enter the Program Mode with the valve in Service. While in the Program Mode, the control will continue to operate normally, monitoring water usage and keeping all displays up to date. Control programming is stored in memory permanently, eliminating the need for battery back-up power.

Meter Immediate Control

A meter immediate control measures water usage and regenerates the system as soon as the calculated system capacity is depleted. The control calculates the system capacity by dividing the unit capacity (typically expressed in grains/unit volume) by the feedwater hardness and subtracting the reserve. Meter Immediate systems generally do not use a reserve volume. However, in twin tank systems with soft-water regeneration, the reserve capacity should be set to the volume of water used during regeneration to prevent hard water break-through. A Meter Immediate control will also start a regeneration cycle at the programmed regeneration time if a number of days equal to the regeneration day override pass before water usage depletes the calculated system capacity.

Meter Delayed Control

A Meter Delayed Control measures water usage and regenerates the system at the programmed regeneration time after the calculated system capacity is depleted. As with Meter Immediate systems, the control calculates the system capacity by dividing the unit capacity by the feedwater hardness and subtracting the reserve. The reserve should be set to insure that the system delivers treated water between the time the system capacity is depleted and the actual regeneration time. A Meter Delayed control will also start a regeneration cycle at the programmed regeneration time if a number of days equal to the regeneration day override pass before water usage depletes the calculated system capacity.

Time Clock Delayed Control

A Time Clock Delayed Control regenerates the system on a timed interval. The control will initiate a regeneration cycle at the programmed regeneration time when the number of days since the last regeneration equals the regeneration day override value.

Day of the Week Control

This control regenerates the system on a weekly schedule. The schedule is defined in Master Programming by setting each day to either "off" or "on." The control will initiate a regeneration cycle on days that have been set to "on" at the specified regeneration time.

Control Operation During a Power Failure

The SXT includes integral power backup. In the event of power failure, the control shifts into a power-saving mode. The control stops monitoring water usage, and the display and motor shut down, but it continues to keep track of the time and day for a minimum of 48 hours.

The system configuration settings are stored in a non-volatile memory and are stored indefinitely with or without line power. The Time of Day flashes when there has been a power failure. Press any button to stop the Time of Day from flashing.

If power fails while the unit is in regeneration, the control will save the current valve position before it shuts down. When power is restored, the control will resume the regeneration cycle from the point where power failed. Note that if power fails during a regeneration cycle, the valve will remain in its current position until power is restored. The valve system should include all required safety components to prevent overflows resulting from a power failure during regeneration.

The control will not start a new regeneration cycle without line power. If the valve misses a scheduled regeneration due to a power failure, it will queue a regeneration. Once power is restored, the control will initiate a regeneration cycle the next time that the Time of Day equals the programmed regeneration time. Typically, this means that the valve will regenerate one day after it was originally scheduled. If the treated water output is important and power interruptions are expected, the system should be setup with a sufficient reserve capacity to compensate for regeneration delays.

Sizing and Operating Requirements

Water Pressure

The water system must have a pump big enough to deliver the recommended backwash rate with a minimum pressure at the inlet of the filter of 20 psi (137 kPa). If the existing system cannot do this, it must be upgraded to do so. Whenever possible, the water system should be adjusted to deliver at least 30 psi (206.8 kPa) for even more satisfactory results. Maximum pressure should not exceed 100 psi (689 kPa).

Backwash Flow Rates

The most important criteria in sizing an iron filter is the capacity of the pump. The water must pass through the filter media at a service flow rate that allows it to oxidize and collect the iron. The filter must also be backwashed at a flow rate sufficient to dislodge and remove the captured iron. Failure to provide sufficient water will cause a build-up of iron in the filter media, impairing its iron removing ability and resulting in iron bleeding out into the service water.

In order for your filter to backwash and rinse properly, your pump must be capable of providing the backwash flow rates indicated in the above specification chart.

Capacity

An iron filter with one cubic foot of filter media regenerated with one Potassium Permanganate feeder will work well for most residential applications. For example, with iron in the range of 3-6 ppm, most filters will need to regenerate every two or three days providing an average family size of four or five people.

The specification chart above shows the iron removal capacity in ppm that can be expected on automatic iron filters. The specifications are based on obtaining 6,000 ppm of capacity for each cubic foot of filter media. Two different Potassium Permanganate feeders are available – one feeding 2 oz. per regeneration, the other feeding 4 oz.

In order to obtain the above capacities, the pH of the water being treated must be 7.0 or above. In the event the water is below 7.0, it must be treated with the appropriate equipment before going through the filter.

Removal of Iron, Manganese & Hydrogen Sulfide

For the purpose of sizing a filter, consider 1 ppm of manganese equal to 2 ppm of iron and 1 ppm of hydrogen sulfide equal to 3 ppm of iron. Manganese and hydrogen sulfide (sulfur) are more difficult to oxidize than iron. Therefore, we suggest that, when making your sizing calculations and regeneration frequency calculations, calculate iron x 1, manganese x 2 and hydrogen sulfide x 3. All three must equal less than 10 ppm. Manganese is often present in water when iron is present. Hydrogen sulfide can normally be identified by a strong rotten egg odor.

Installation Instructions

All government codes and regulations governing the installation of these devices must be observed.

CAUTION: If the ground from the electrical panel or breaker box to the water meter or underground copper pipe is tied to the copper water lines and these lines are cut during installation of the Noryl bypass valve and/or poly pipe, an approved grounding strap must be used between the two lines that have been cut in order to maintain continuity. The length of the grounding strap will depend upon the number of units being installed and/or the amount of copper pipe being replaced with poly. See Figure 1.

In all cases where metal pipe was originally used and is later interrupted by poly pipe or the Noryl bypass valve as in Figure 1 or by physical separation as in Figure 2, an approved ground clamp with no less than #6 copper conductor must be used for continuity, to maintain proper metallic pipe bonding.

Check your local electrical code for the correct clamp and cable size.

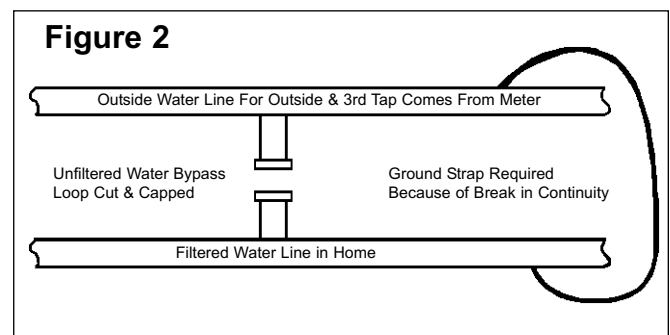
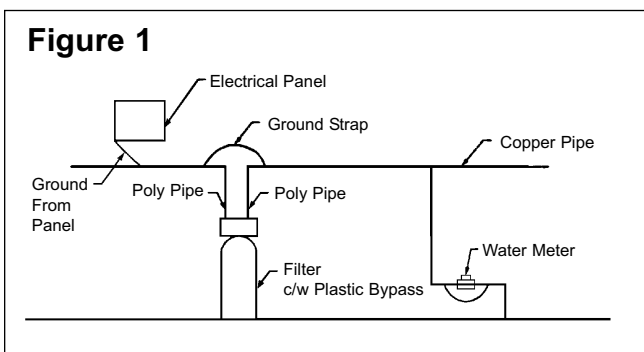

- Place the iron filter and the chemical feeder container on a flat surface in desired location, near a drain and 120 volt AC outlet. Subjecting your filter to freezing or to water temperatures above 110°F (43°C) will void the warranty.

NOTE: Some units are shipped with the media bed in separate bags. To install, unscrew the control valve from the top of the fiberglass tank, position the riser tube in the center of the tank plugging the tube with a cloth and pour the media into the tank in the following order: coarse, fine gravel and then the filter media. Remove the cloth and carefully screw the valve into the tank (When replacing the media, the tank must first be inverted and the old media bed removed. See instructions provided with the replacement media).

Rural Well Supply - Iron & Hardness Removal

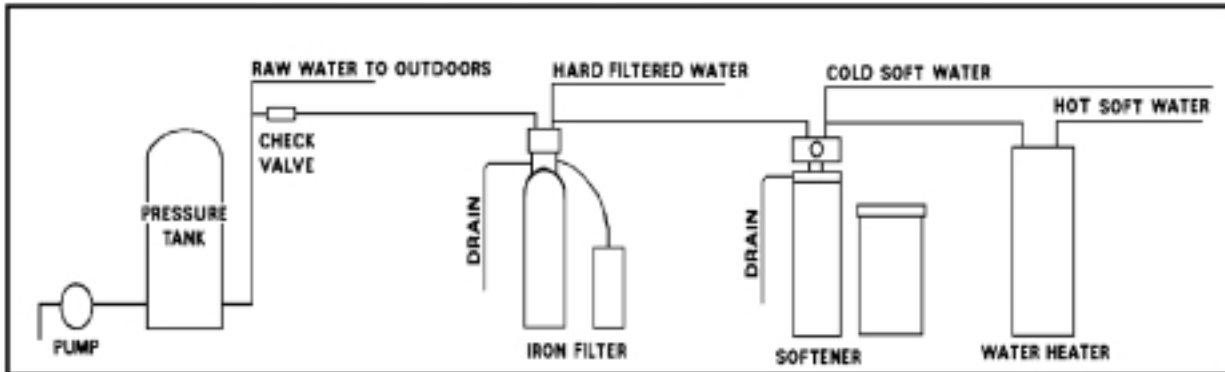

- Attach the installation kit or bypass to the control valve. Make the inlet and outlet connections to meet applicable plumbing codes. A 3/4" inlet line is recommended. When sweat fittings are used, solder the adapters for the inlet and outlet to a short length of copper pipe first. This procedure is necessary because the controls **MUST NOT** be subjected to temperatures above 160°F (71°C). Then, using Teflon tape, screw the adapters for the inlet, outlet and drain into the valve.
CAUTION: Do not use pipe thread compound as it may attack the material in the valve body.
- On the drain, use the 1/2" hose barb supplied and a full 1/2" ID hose (not supplied) for the drain line and make the shortest run to a suitable drain. The drain lines must be secured in position at the ends which discharges into the drain so it cannot be inadvertently moved from the drain, resulting in chemical spillage.
- Connect the feeder container to the control valve with the flexible polyethylene tubing provided. The connection to the container is made with the fitting nut provided (do not overtighten).
- Attach the 5/8" hose (supplied) to the over flow fitting on the feeder and run the hose to the floor drain.
- Make sure the bypass valve is in the service position.
- Plug the 24-volt transformer into a 120 VAC 60 Hz outlet. This valve has four positions: 1) Backwash 2) Brine/Rinse 3) Rapid Rinse and 4) Brine Refill. When the valve is in the Service position, the *extra cycle* button (far left button as shown on Figure 4) must be pressed and held for 5 seconds before it activates. Press and hold the *extra cycle* button for 5 seconds to advance the valve to the "1" Backwash position. Slowly turn on the water supply and allow the unit to backwash until the air purges out of the tank and clears the system.
- Advance to the brine refill position "4". Allow to fill for 5 minutes. Make sure there are no leaks in the top connection to the feeder container.
- Advance to the Brine/Rinse position "2". Proper draw is indicated by upward motion of water droplets in the tube connected to the feeder container. Allow to draw for 5 minutes to pull the air out of the feeder container.
- Put control into the service position.
- Set the time of day and gallons between regeneration following the information on Pages 5-8.
- Make sure any bypass is in the service position.
- Cautiously pour the Potassium Permanganate into the feeder and replace the cover and safety screws. (See the refilling instructions on page 10).
- Manually initiate regeneration after about one hour for the potassium permanganate to activate the manganese greensand.

ALL STATE AND LOCAL GOVERNMENT CODES GOVERNING INSTALLATIONS OF THESE DEVICES MUST BE OBSERVED.

Operating Instructions

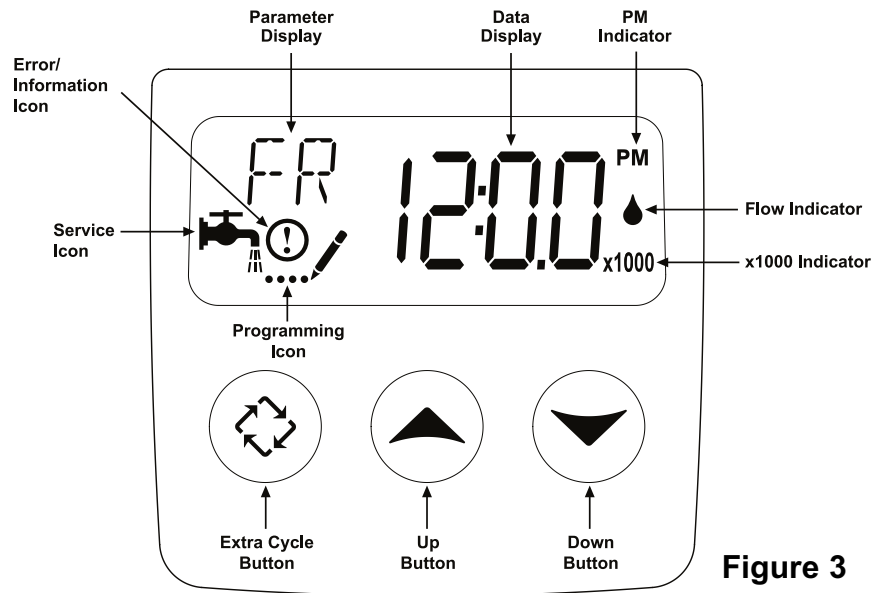

Figure 3

The valve has been pre-programmed with factory settings as follows:

Regeneration Cycle Step Programming

1. Backwash10 minutes
2. Brine Rinse50 minutes
3. Rapid Rinse10 minutes
4. Brine Refill4 minutes

Whenever the valve is in Service the current time of day can be set, the control programmed, or an extra regeneration initiated at any time.

Set Time of Day

1. Press and hold either the Up or Down buttons until the programming icon replaces the service icon and the parameter display reads TD.
2. Adjust the displayed time with the Up and Down buttons.
3. When the desired time is set, press the Extra Cycle button to resume normal operation. The unit will also return to normal operation after 5 seconds if no buttons are pressed.



Queueing a Regeneration

1. Press the Extra Cycle button. The service icon will flash to indicate that a regeneration is queued.
2. To cancel a queued regeneration, press the Extra Cycle button.

Regenerating Immediately

Press and hold the Extra Cycle button for five seconds.

Installation Tip: The 5600SXT Filter should not be allowed to regenerate at the same time as any other water treatment units. If adjustment is required, consult programming chart to adjust default regeneration time. Default setting is 11:00 pm.)

User Programming Mode Options		
Abbreviation	Parameter	Description
DO	Day Override	The timer's day override setting THIS IS AN OPTION ONLY. PLEASE DO NOT ADJUST BEFORE CONSULTING AN AUTHORIZED DEALER.
RT	Regeneration Time	The time of day that the system will regenerate (meter delayed, timeclock, and day-of-week systems)
H	Feed Water Iron Content	The iron content in ppm of the inlet water - used to calculate system capacity for metered systems
RC	Reserve Capacity	The fixed reserve capacity
CD	Current Day	The current day of week

NOTES:

Some items may not be shown depending on timer configuration.

The timer will discard any changes and exit User Mode if any button is not pressed for sixty seconds.

User Programming Mode Steps

1. Press the Up and Down buttons for five seconds while in service, and the time of day is NOT set to 12:01 PM.
2. Use this display to adjust the Day Override. This option setting is identified by "DO" in the upper left hand corner of the screen.

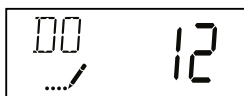

THIS IS AN OPTION ONLY. PLEASE DO NOT ADJUST BEFORE CONSULTING AN AUTHORIZED DEALER.

3. Press the Extra Cycle button. Use this display to adjust the Regeneration Time. This option setting is identified by "RT" in the upper left hand corner of the screen.

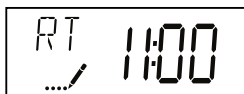

4. Press the Extra Cycle button. Use this display to adjust the Feed Water Iron Concentration in ppm. This option setting is identified by "H" in the upper left hand corner of the screen.

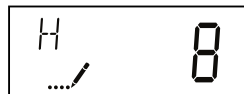

5. Press the Extra Cycle button. Use this display to adjust the Fixed Reserve Capacity. This option setting is identified by "RC" in the upper left-hand corner of the screen.

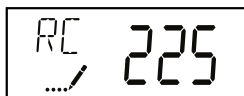

# of People	RC
1	75
2	150
3	225

6. Press the Extra Cycle button to end User Programming Mode.

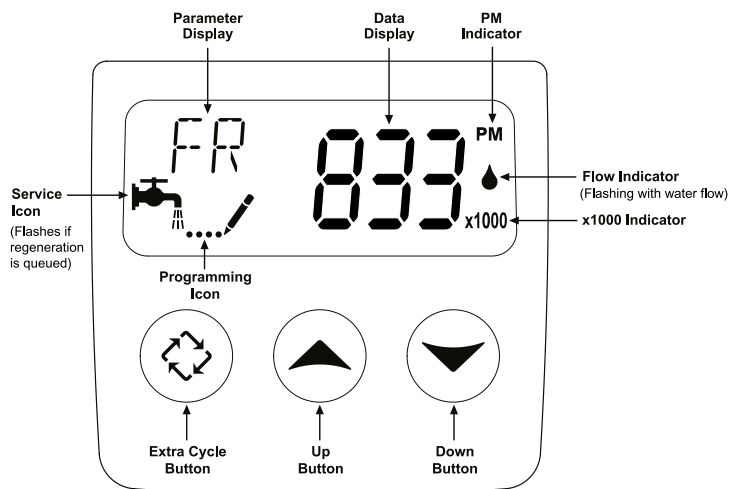

Error Codes

Note: Error codes appear on the *In Service* display

Error Code	Probable Cause	Recover and Resetting
[Err 0]	Drive motor is stalled	Unplug the unit from the power source
[Err 1]	Drive motor is running continuously	When power is restored to the unit, the Err _ display code clears. If the condition causing the error has not been resolved the Err _ code reappears in the four digit display. Do not attempt to troubleshoot this problem any further.
[Err 2]	<p>There have been more than 99 days since the last Regeneration. If the Day of the Week mode of regeneration is selected and days since last regeneration exceeds 7 days.</p> <p>[7 - - 5]: There have been more than 7 days since the last regeneration. All individual settings (d1, d2, d3, d4, d5, d6, d7) are set to 0.</p>	<p>Regeneration must occur for the unit to recover, the display to clear and the valve to function normally.</p> <p>[7 - - 5]: To recover from [Err2], the user must initiate a regeneration or set at least one individual day to 1.</p>
[Err 3]	Control board memory failure.	Perform a Master Reset. If the error returns, do not attempt to troubleshoot this problem any further.

Error Display Example



NOTE: Unit will flash when an error exists.

To determine the frequency of regeneration, use this procedure:

Setting the Frequency of Automatic Regeneration (SXT Models)

Please enter the ppm of compensated iron per gallon of water to be removed. See Step #4 of "User Programming." The SXT valve will automatically calculate the number of gallons of water to be treated by the iron filter between regenerations.

Iron Content in the Feed Water:

ppm of capacity between regenerations (see Specifications - Page 1)

÷ ppm of iron in the water sample*
= number of gallons supplied between regenerations
- reserve capacity (number of people x 75 gallons)

Example - Using 5600 SXTM-948IF + 1 Feeder

	6000	ppm between regenerations
÷	<u>8</u>	ppm of compensated iron [To be entered by the user]
=	750	gallons between regenerations [See step #5 of "User Programming"]
-	<u>375</u>	gallons reserve capacity (5 people x 75 gallons)
=	375	GALLONS - BETWEEN REGENERATIONS [Calculated by valve]

*** 1 ppm of manganese = 2 ppm of iron; 1 ppm of hydrogen sulfide = 3 ppm of iron**

Days:

Total amount of iron to be removed between regenerations -

÷ ppm of iron to be removed per day
= NUMBER OF DAYS BETWEEN REGENERATIONS

Example:

	5	people in the household
x	<u>75</u>	gallons of filtered water per person
=	375	gallons of filtered per day
x	<u>8</u>	ppm of compensated iron
=	3,000	PPM OF IRON TO BE REMOVED PER DAY

Using 5600 SXTM-948IF + 1 Feeder

	6,000	ppm capacity
÷	<u>3,000</u>	ppm to be removed per day
=	2**	DAYS BETWEEN REGENERATIONS

**Maximum number of days between regenerartions should be 12.

Manual Regeneration Cycle

If you run out of filtered water because of inadequate regeneration frequency, inadequate reserve capacity, power failure or unusually high water usage, you can initiate a manual regeneration simply by pressing the extra cycle button. The filter will now automatically complete a regeneration cycle and return to service. If possible, avoid water use during the regeneration cycle.

Once you have set your filter you may experience frequent loss of water pressure, you may have to increase the frequency of regeneration by decreasing the number of gallons between regeneration.

Potassium Permanganate Feeder

The potassium permanganate feeder assembly incorporates a non-pressurized storage tank and innovative new grid design along with a dependable float valve.

The attractive 10" x 16" black tank is made of tough blow-molded high density polyethylene. It has a potassium permanganate capacity of 30 lbs. and a liquid capacity of 5 gallons.

The black injection molded cover is securely fastened with three stainless steel safety screws to prevent access by children and pets. Also, the potassium chemical tank should be placed where it is free from possible upset or access by children or pets.

Chemical warning label and drain caution label are affixed to unit.

The unique polypropylene grid pad refuses to allow even the finest grade of undissolved potassium permanganate to pass through the grid. This permits efficient use of our assembly with all grades of potassium permanganate. Standard grid platform height is 6". Additional heights are available - consult factory.

The unit is shipped fully tested and assembled and weighs approximately 7 lbs. The feeder assembly includes:

- 10" x 16" black tank
- 3 Stainless steel safety screws
- 4" Well and cap
- 15 ft of 5/8" x 1/2" poly drain tubing*
- Drain caution label
- 1/4" PVC riser pipe
- 1/4" or 3/8" poly tube elbow

- Black injection molded cover
- Grid with polypropylene grid pad
- Float valve
- Chemical warning label
- 4 ft of 1/4" or 3/8" suction tubing
- 1/2" Overflow fitting

The potassium storage tank placement should be such to permit the installation of the overflow line to a permanent drain facility.

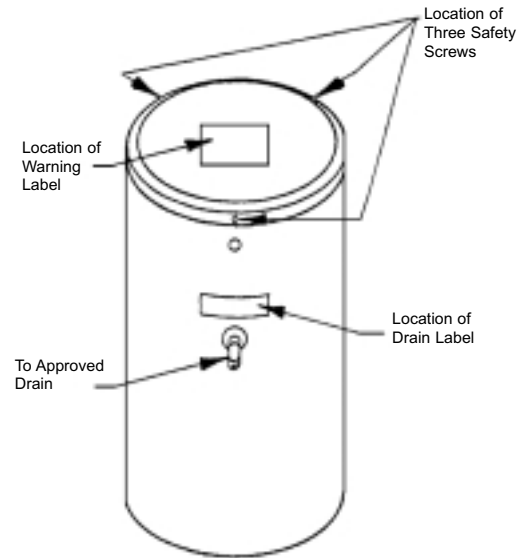
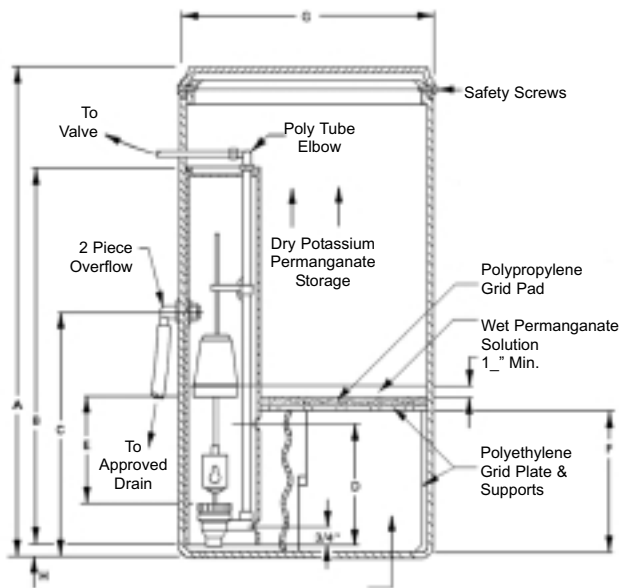

Dimensions - Inches

- A = 16-1/2" E = See Table
- B = 14-1/2" F = 5-3/4" (2 oz. to 4 oz.)
- C = 10-1/2" 7-5/8" (6 oz.)
- D = 5-1/4" G = 10-1/2"
- H = 1/8"

Oz. Of Potassium Permanganate	Gallons of Solution	Float Setting	Riser Pipe Length
2	3/4	2-1/2	11
4	1	4	12-1/2
6	1-1/2	5-5/8	12-1/2

Correct water temperature is important for obtaining properly dissolved potassium permanganate.

Tables based on permanganate solubility of 4 oz/gal at 50°F or 8 oz/gal at 72°F.

Float setting is based on distance between brine valve top body nut and the bottom of the float with the valve in the closed (float up) position.

All dimensions nearest 1/4 inch.

Iron and Manganese Removal

A recommended dose of 2 oz. to 6 oz. of potassium permanganate per cubic foot of manganese greensand is suggested for regeneration. Correct water temperature is important in obtaining proper dissolving of potassium permanganate. At 50°F (10°C), 4 oz. of potassium permanganate can dissolve in one gallon of water. At room temperature 72°F (22°C), 8 oz. will dissolve in one gallon of water.

Operating Instructions

Sounds

You will notice new sounds as your filter operates such as the hum of the timer or click of the actuator arm. During regeneration, it will not be uncommon to hear the sounds of water running to the drain.

Manual Bypass (Figure 4)

In case of an emergency you can isolate your water filter from the water supply using the bypass valve located at the back of the control.

In normal operation the bypass is open with the ON/OFF knobs in line with the INLET and OUTLET pipes. To isolate the filter, simply rotate the knobs clockwise (as indicated by the word BYPASS and arrow) until they lock.

You can use your water related fixtures and appliances as the water supply is bypassing the filter. However, the water you use will be untreated.

To resume filtered water service, open the bypass valve by rotating the knobs counter-clockwise.

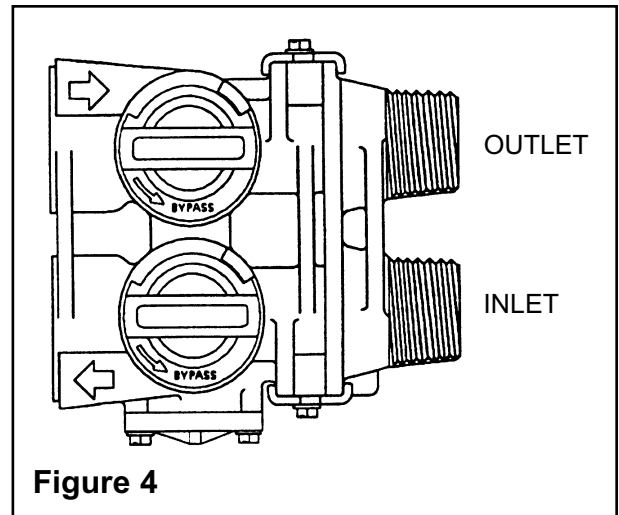

Figure 4

Maintenance Instructions

Maintenance of your new water filter requires very little time or effort but it is essential. Regular maintenance will ensure many years of efficient and trouble free operation.

PLEASE NOTE: THE FOLLOWING MAINTENANCE PROCEDURES MUST BE PERFORMED REGULARLY FOR YOUR GUARANTEE TO BE VALID.

Cleaning The Injector Assembly (Figure 5)

The presence of iron and sediment will restrict and clog the injector assembly which is located on the right hand side of the control valve. This assembly is easy to clean.

Shut off the water supply to your unit and reduce the pressure by turning the large knob to backwash. Using a screwdriver, remove the two screws holding the injector assembly to the control valve body. Carefully remove the assembly and disassemble.

The injector nozzle is removed for the injector body by carefully turning it out with a large screwdriver. Carefully flush all parts with water. Use a mild acid such as vinegar or Iron Out to clear the small holes in the nozzle and throat. Reassemble using the reverse procedure.

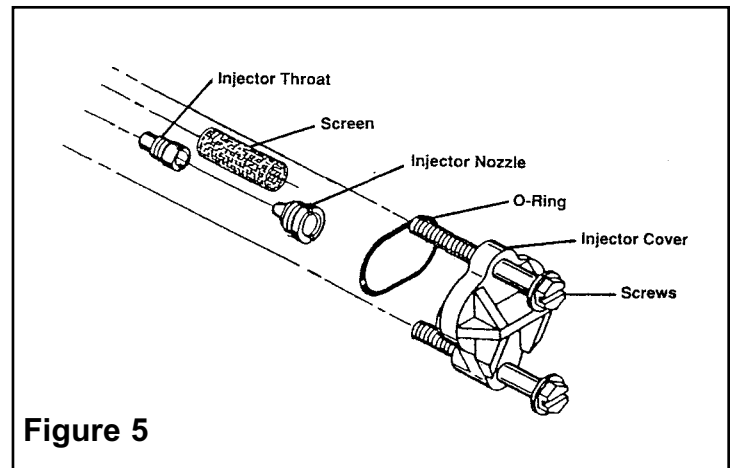

Figure 5

Care Of Your Filter

Your filter tank and chemical feeder container can be cleaned with a mild soap solution. Never subject the unit to freezing. Do not strike or drop the chemical feeder container. If the container is found to be leaking, shut off the water supply to your filter and replace the container at once.

Trouble Shooting Guide

PROBLEM	CAUSE	CORRECTION
1. Filter fails to regenerate or regenerates at wrong times	<ul style="list-style-type: none"> A. Electrical service to unit has been interrupted B. Timer is defective C. Power failure D. Timer motor does not run 	<ul style="list-style-type: none"> A. Assure permanent electrical service (check fuse, plug or switch) B. Repair or replace timer C. Reset time of day D. Replace defective motor
2. Filter bleeds iron or odor	<ul style="list-style-type: none"> A. Bypass valve is open B. Container is depleted C. Excessive water usage D. Insufficient water flowing into chemical container E. Hot water tank rusty F. Leak at distributor tube G. Defective or stripped media bed H. Not backwashing enough I. Internal valve leak J. Electrical Service to unit has K. Control will not draw chemical properly (see below) L. Quality of water has worsened M. Filter capacity is too small 	<ul style="list-style-type: none"> A. Close bypass valve B. Replace or refill container C. Increase frequency of regeneration and/or settings. Make sure there are no leaks in toilets and sinks D. Check refill setting. Check for plugged container tube and flow control E. Repeated flushings of the hot water tank are required. Do not use hot water during regeneration F. Make sure distributor tube is not cracked. Check O-ring and tube pilot G. Replace media H. Be sure flow control is not clogged or drain line restricted. Be sure water pressure has not dropped and that pump has sufficient capacity. I. Replace seals and spacers and/or piston J. Assure permanent electrical service (check been interrupted fuse, plug or switch) K. Maintain water pressure at 20 psi (139.9 kPa) minimum. Clean or replace injector assembly. Check for air leaks along brine line and tighten all connections. L. Have water sample analysed to determine any change M. Replace with larger unit
3. Filter regenerates every day	<ul style="list-style-type: none"> A. Faulty gear train 	<ul style="list-style-type: none"> A. Check the mechanical linkage on the timer control to eliminate possible binding in the gear train.
4. Iron filter uses too much chemical	<ul style="list-style-type: none"> A. Defective chemical container 	<ul style="list-style-type: none"> A. Replace container
5. Loss of water pressure	<ul style="list-style-type: none"> A. Iron or turbidity build-up in filter B. Inlet to control blocked with iron build-up or foreign matter 	<ul style="list-style-type: none"> A. Increase frequency of regeneration so filter backwashes more often. NOTE: Make sure filter is sized large enough to handle water usage B. Clean inlet line. Remove piston and clean control.
6. Loss of media through line	<ul style="list-style-type: none"> A. Air in water system B. Backwash rate too fast 	<ul style="list-style-type: none"> A. Assure that well system has proper air eliminator control. Check for dry well condition. B. Check drain flow control for proper flow rate

PROBLEM	CAUSE	CORRECTION
7. Iron filter fails to draw chemical	<ul style="list-style-type: none"> A. Drain line flow control is plugged B. Injectors and/or screen plugged C. Line pressure is too low D. Internal control leak 	<ul style="list-style-type: none"> A. Clean drain line flow control B. Clean or replace injectors and/or screen C. Maintain line pressure at 20 psi (139.9 kPa) minimum D. Change seals and spacers and/or piston assembly
8. Drain flows continuously	<ul style="list-style-type: none"> A. Foreign material in control B. Internal control leak C. Control valve jammed in brine or backwash position D. Timer motor stopped or jammed 	<ul style="list-style-type: none"> A. Remove piston assembly and inspect bore, remove foreign material and check control in various regeneration positions B. Change seals and spacers and/or piston assembly C. Replace piston and seals and spacers (and drive motor if necessary) D. Replace timer motor
9. Pink color (potassium permanganate) present after regeneration; medicinal water taste	<ul style="list-style-type: none"> A. Poor water pressure or insufficient pump capacity B. Chemical in water supply 	<ul style="list-style-type: none"> A. Be sure pump is set at 20 psi (139.9 kPa) minimum and is capable of producing 5 - 12 USGPM according to filter size B. Decrease frequency of regeneration

GUARANTEE

HYDROTECH guarantees that your new water conditioner is built of quality material and workmanship. When properly installed and maintained, it will give years of trouble-free service.

FIVE YEAR COMPLETE PARTS GUARANTEE

HYDROTECH will replace any part which fails within 60 months from date of manufacture, provided the failure is due to a defect in material or workmanship. The only exception shall be when proof of purchase or installation is provided and then the warranty period shall be from the date thereof.

TEN YEAR GUARANTEE ON MINERAL TANKS

HYDROTECH will provide a replacement mineral tank to any original equipment purchaser in possession of a tank that fails within 120 months, provided that the water conditioner is at all times operated in accordance with specifications and not subject to freezing or exposure to direct sunlight.

GENERAL PROVISIONS

HYDROTECH assumes no responsibility for consequential damage as a result of escaped water from the water filter; labor or expense incurred as a result of a defect or for failure to meet the terms of these guarantees because of circumstances beyond its control.