



# **5600 Meter Initiated Valve**

---

## **Water Softener Operation Manual**



# Performance and Specifications

Item Number	Model Number	Capacity at regeneration salt levels (kilograins as CaCO <sub>3</sub> )			Service Flow Rate USGPM (LPM)	Maximum Flow To Drain USGPM (LPM)	Mineral Tank Size inches (mm)	Brine Tank Size inches (mm)	Resin Volume cu.ft. (litres)	Salt Capacity Lbs. (kg)	Shipping Weight Lbs. (kg)
		@15lb/cf	@10lb/cf*	@6lb/cf							
<b>Twin Tank Models</b>											
7600	5600MI-20	22	20	15	8.0 (30.3)	1.2 (4.5)	8 x 47 (203 x 1194)	18 x 35 (457 x 889)	0.75 (21.2)	224 (101.6)	90 (40.8)
7601	5600MI-30	30	27	20	10.0 (37.9)	1.5 (5.7)	9 x 48 (229 x 1219)	18 x 35 (457 x 889)	1.00 (28.3)	224 (101.6)	105 (47.6)
7602	5600MI-45	45	41	30	11.0 (41.6)	2.0 (7.6)	10 x 54 (254 x 1372)	21 x 36 (533 x 914)	1.50 (42.5)	308 (139.7)	140 (63.5)
7603	5600MI-60	60	55	40	15.0 (56.8)	3.0 (11.4)	12 x 52 (305 x 1321)	21 x 36 (533 x 914)	2.00 (56.6)	308 (139.7)	185 (83.9)
7604	5600MI-90	90	82	60	15.0 (56.8)	4.0 (15.1)	14 x 65 (356 x 1651)	21 x 36 (533 x 914)	3.0 (84.5)	308 (139.7)	255 (115.7)
<b>Cabinet Models</b>											
7378	WTC5620	20	18	13	6 (22.7)	1.2 (4.5)	8 x 35 (203 x 889)	21x13x44 (533x330x1118)	0.67 (19)	359 (163)	73 (33)
7379	WTC5630	30	27	20	10 (37.9)	2.0 (7.6)	10 x 35 (254 x 889)	21x13x44 (533x330x1118)	1.00 (28)	359 (163)	90 (41)

**Caution:** These water conditioners are not intended to be used for treating water that is microbiologically unsafe or of unknown quality without adequate disinfection before or after the system.

**Notes:**

**Operating Temperature Range:** 110°F (43°C)  
**Operating Pressure Range:** 100 psig (689 kPa)  
**Electrical:** Standard 110V  
**Pipe size:** 3/4"

1. "\*" designates that 10 lb/cf is the factory salt setting for all units.
2. Capacities of softeners may deviate from the chart above depending on flow rates and raw water conditions.
3. The manufacturer reserves the right to make product improvements which may deviate from the specifications and descriptions stated herein without obligation to change previously manufactured products or to note the change.
4. 1 Kilograin is equal to 1000 grains.

## How Your 5600 MI-DF Water Conditioner Works

Hard water enters your home through the main supply line, enters your water conditioner, and passes down through a bed of ion exchange resin which softens and filters the water as well. An ion exchange process takes place in which the resin beads capture and hold calcium and magnesium, the hardness impurities, while the water takes on sodium ions. The soft water then flows up and into your household water line.

Your meter initiated water conditioner is set by aligning the number of people with the grains of hardness on the program wheel. See page 4.

On the days your conditioner regenerates, the resin is automatically recharged by passing a brine solution (salt water) through it. This reverses the ion exchange process, charging the resin with sodium and freeing the hardness minerals. These minerals and the brine solution are then flushed away through the drain line followed by a rapid rinse. The resin bed is again ready to soften water. The proper volume of water is returned to the brine tank to dissolve enough salt for the next regeneration. All this is performed automatically.

## Installation Instructions

**CAUTION:**

If the ground from the electrical panel or breaker box to the water meter or underground copper pipe is tied to the copper water lines and these lines are cut during installation of the Noryl bypass valve and/or poly pipe, an approved grounding strap must be used between the two lines that have been cut in order to maintain continuity. The length of the grounding strap will depend upon the number of units being installed and/or the amount of copper pipe being replaced with poly. See Figure 1.

In all cases where metal pipe was originally used and is later interrupted by poly pipe or the Noryl bypass valve as in Figure 1 or by physical separation as in Figure 2, to maintain proper metallic pipe bonding, an approved ground clamp c/w not less than #6 copper conductor must be used for continuity.

Check your local electrical code for the correct clamp and cable size.

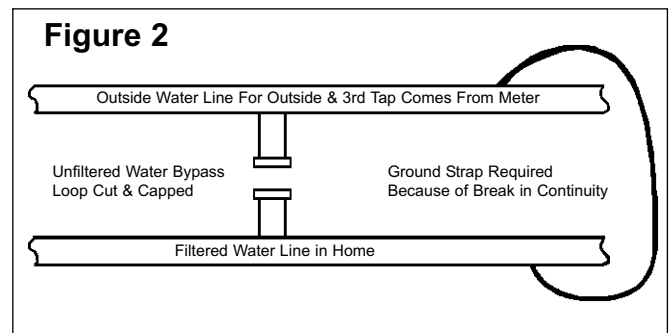
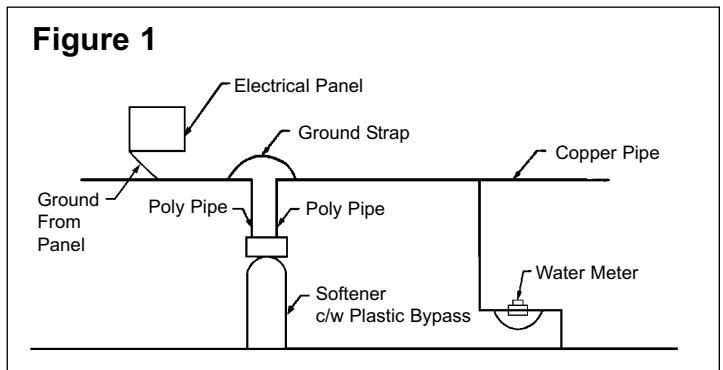

# Installation Instructions

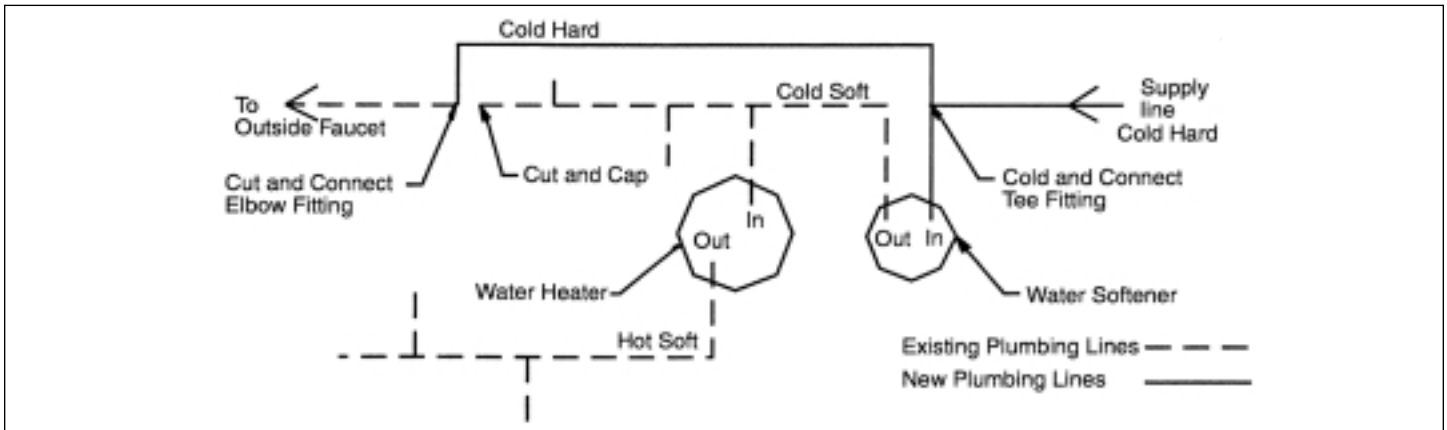

1. Determine the best location for your water softener, bearing in mind the location of your water supply lines, drain line and 110 volt AC electrical outlet. Subjecting the softener to freezing or temperatures above 110°F (43°C) will void the warranty.

## Media Installation (When Necessary)

- Remove the valve from the mineral tank.
- Temporarily plug the open end of the riser tube to ensure that no resin or gravel falls down into the distribution.
- Fill mineral tank one quarter full of water to protect distribution during gravel installation.
- Slowly and carefully add the gravel support bed and the softener or filtration media leveling each layer as it is placed into the tank.
- Unplug the riser tube, carefully position the valve over it and turn the valve into the threads in the fiberglass tank, tightening securely into tank. Note: Ensure that the internal O-ring in the valve fits securely over the riser tube. Silicone grease (#13691) or other food grade lubricant may be applied to the O-ring to ease installation of the riser tube. DO NOT use petroleum based lubricants as they will cause swelling of O-ring seals.
- The softener or filter is now charged with softening resin.

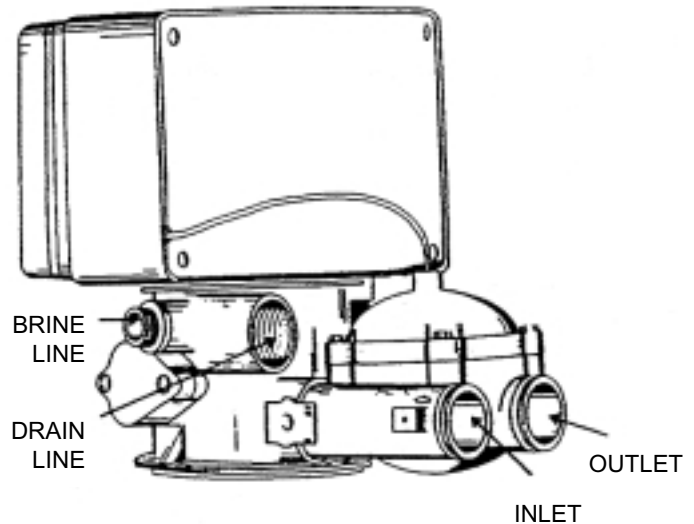

**Rear View - Plumbing Hook-Up**

- It is recommended that the softener or filter tank now be completely filled with water (SLOWLY) to soak the resin or filtration media before startup. This will allow the media to absorb water as well as help displace any trapped air. This will reduce the chance of backwashing resin or filter media out of the tank during the initial backwash on startup.
2. Water to supply outside faucets used to water lawns and gardens should not be softened. A new water line is often required to be connected to supply hard water to the inlet of the water softener and to the outside faucets. Cut the water line between where it enters the house; before any lines that branch off to feed the hot water heater or other fixtures in the house; and as near the desired location of the water softener as possible. Install a tee fitting on the feed end of the cut pipe and an elbow fitting on the other end. Install piping from the tee to the inlet of the water softener and from the elbow to the outlet to the softener. To serve the water lines which branch off to feed outside faucets, cut the branch lines approximately two inches from the fitting on the main water line. Install an elbow on the end of the pipe nearest the outside faucet and a cap on the end connected to the existing water line. Install piping from the tee on the inlet to the water softener to the elbow on the pipe to the outside faucet. Following this procedure will result in all lines in the house, with the exception of the outside faucets but including the water heater and therefore the hot water lines, being supplied with soft water.

3. Familiarize yourself with the location of the inlet, outlet and drain on the control valve. Be very careful not to get the controls wet.
4. Attach the bypass valve to the control valve. Connect the inlet and outlet of the water softener to the plumbing in the house. The control valve must not be subjected to temperatures above 71°C (160°F). To avoid damaging the control valve when sweat fittings are used, solder the threaded copper adapters to the copper pipe and then, using teflon tape, screw the assembly into the bypass valve.

**CAUTION** - do not use pipe thread compound as it may attack the material in the valve body.

5. Using teflon tape, screw the 1/2" hose barb into the drain port in the valve. Attach 1/2" drain hose to the hose barb and tighten securely with a hose clamp. Run the drain line to a floor drain or a laundry drain. Complete any necessary plumbing.
6. On the twin tank units, pull the 3/8" brine line through the hole in the side of the brine tank. Connect the brine line to the fitting on the side of the valve using the nut and ferrule. Tighten snugly.
7. Make sure the bypass valve is in the service position.
8. Set the time of day and the program wheel according to the instructions on page 4.
9. Remove back cover plate. Make sure that the salt dosage is set as recommended on page 5.

NOTE: The various regeneration positions may be dialed manually by turning the large knob on the front of the control clockwise, until the indicator shows the desired position.

10. Turn the large knob to the backwash position. Turn on the water supply to the valve and wait until water starts running at the drain. Allow the water to run at the drain for 2 to 3 minutes.
11. Turn the knob advancing the valve to the brine and rinse position. Allow the water to run at the drain for a further 2 to 3 minutes. Using the same procedure, turn the knob to rapid rinse position and allow to run for a few minutes.
12. Plug the conditioner in. Manually turn the knob to the start of the brine refill position. The correct amount of water will be automatically metered through the air check tube in the brine well into the brine tank, and the control will automatically return to the service position. The service position is indicated by the word SERVICE on the front dial.
13. Replace back cover on the control module.
14. Put a minimum of 40 kg of crystal water softener salt in the brine tank. The unit will automatically fill to the correct level when it regenerates.

**ALL STATE AND LOCAL GOVERNMENT CODES GOVERNING INSTALLATION OF THESE DEVICES MUST BE OBSERVED.**

**Optional Sanitization Procedure:** We recommend that all new water conditioners be disinfected as part of the startup. Sanitization is achieved by the application of chlorine in the regeneration cycle of the conditioner. A liquid solution of 5.25% sodium hypochlorite (commonly referred to as household bleach) is recommended as a suitable disinfectant. Use only unscented products. For every cubic foot of resin in the softener, pour approximately two (2) tablespoons of sodium hypochlorite into the brine well tube. The brine tank refill in Step 12 should add the correct amount of water to the brine tank. If not, the water can be added manually now. Press and hold the EXTRA CYCLE button to begin a manual regeneration. Press the EXTRA CYCLE button again to advance the valve to the Brine/Rinse position. Allow softener to complete the Brine/Rinse cycle, then let the manual regeneration continue until the brine tank is refilled again with the correct amount of water.

# Operating Instructions

## Setting the Time of Day (Figure 3)

This is a 24-hour timer and must correspond with the correct time on your wrist watch to ensure proper cycling of your conditioner. Disengage the drive gear by pressing and holding in the RED BUTTON on the left side of the control. Now turn the large 24-hour gear until the actual time of day is at the time of day arrow at the bottom of the panel. Release the red button to re-engage the drive gear. The correct time of day on the 24-hour clock has now been set.

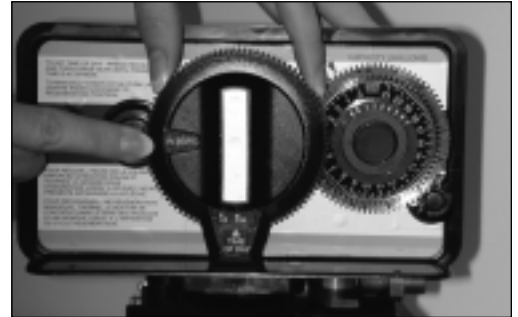

Figure 3

## Time of Regeneration

The time of regeneration is factory set at 2:00 a.m.

## Manual Regeneration Cycle (Figure 4)

Should you run out of soft water due to inadequate frequency of regeneration or inadequate reserve capacity, power failure, lack of salt, or excessive usage because of unexpected company, you can initiate a manual regeneration simply by turning the manual regeneration knob on the front of the control to "REGEN" position. The conditioner will now automatically complete a regeneration cycle and return to service. Be sure there is adequate salt and salt brine in the brine tank for a satisfactory regeneration.



Figure 4

## Setting the Regeneration Frequency

There are only two methods for setting the program wheel, use only one of the following methods.

### Setting the Program Wheel – Method 1 (See Figure 5)

Set the program wheel by lifting the "people" dial and rotating it so the number of people in the household is aligned with the grains per gallon water hardness scale. Release the dial and check for firm engagement at setting. (This method will provide reserve capacity based on 75 gallons per person per day.)

### Setting the Program Wheel – Method 2

The frequency of automatic regeneration can alternatively be set by using the gallon label and the small white dot on the program wheel. Set the program wheel by lifting the "people" dial and while pulling it towards you, turn it until the desired number of gallons is aligned with the white dot on the circumference. The number of gallons is read by multiplying the number on the label by 100. To determine the number of gallons of softened water that can be produced between regenerations, use the following formula.

#### Step 1

Capacity between regenerations (see Specifications on page 1). Example: Model 5600MI30 = 27,000 grains @ 10 lbs of salt. Assume 25 grains/gal, divided by grains of hardness in water sample which equates to the number of gallons between regenerations.

Example:  $27,000 \div 25 = 1,080$  gal.

#### Step 2

The advantage to setting the program wheel by method 2 is that you decide how much reserve capacity you want your unit to have. Method 1 assumes water usage of 75 gallons per day. However, if you want more or less reserve, simply assume more or less water usage per person a day. The next step in the example assumes that the water usage will be less and therefore, the unit will not need the extra reserve capacity.

Number of gallons between regeneration

- Reserve capacity (Number of people x 75 gallons)
- = Number of gallons at which to set the program wheel

NOTE: Add one person if you have a dishwasher.



Figure 5

Frequency of Automatic Regeneration  
Meter Initiated Models Only

## Salt Settings are factory set and should not need adjustment

5600MI-20 .....	8 lbs
WTC5620 .....	7 lbs
5600MI-30 .....	10 lbs
WTC5630 .....	10 lbs
5600MI-45 .....	15 lbs
5600MI-60 .....	10 lbs
5600MI-90 .....	15 lbs

## Automatic Bypass

The regeneration cycle lasts approximately 2-1/2 hours, after which soft water service will be restored. During regeneration, hard water is automatically bypassed for use in the household. Hot water should be used as little as possible during this time to prevent hard water from filling the water heater. This is why automatic regeneration is set for sometime during the night and manual regenerations should be performed when little or no water will be used in the household.

## Safety Float

The brine tank is equipped with a safety float which prevents your brine tank from overflowing as a result of a malfunction such as a power failure.

## Water Pressure

Your softener is designed to operate under normal water pressures from 20 psi (1.4 atm) to 120 psi (8.2 atm).

## New Sounds

You may notice new sounds as your water softener operates. The regeneration cycle lasts approximately 2-1/2 hours. During this time, you may hear water running intermittently to the drain.

## Manual Bypass (Figure 6)

In the case of emergency, such as an overflowing brine tank, you can isolate your water softener from the water supply using the bypass valve located at the back of the control.

In normal operation the bypass is open with the on/off knobs in line with the inlet and outlet pipes. To isolate the softener, simply rotate the knobs clockwise (as indicated by the word BYPASS and arrow) until they lock.

You can use your water related fixtures and appliances as the water supply is bypassing the softener. However, the water you use will be hard.

To resume soft water service, open bypass valve by rotating the knobs counter-clockwise.

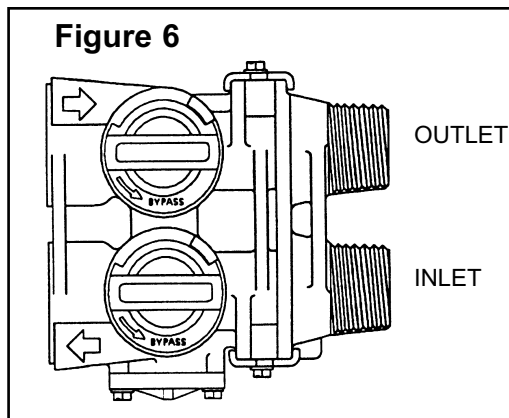

# Maintenance

## Checking the Salt Level

Check the salt level monthly. Remove the lid from the cabinet or brine tank, make sure salt level is always above the brine level (you should not be able to see water).

## Adding Salt

Use only clean salt labeled for water conditioner use, such as crystal, pellet, nugget, button or solar. The use of rock salt is discouraged because it contains insoluble silt and sand which build up in the brine tank and can cause problems with the system's operation. Add the salt directly to the tank, filling no higher than the top of the brine well.

## Caution

Liquid brine will irritate eyes, skin and open wounds - gently wash exposed area with fresh water. Keep children away from your water conditioner.

## Bridging (Figure 7)

Humidity or wrong type of salt may create a cavity between the water and the salt. This action, known as "bridging", prevents the brine solution from being made, leading to your water supply being hard.

If you suspect salt bridging, carefully pound on the outside of the brine tank or pour some warm water over the salt to break up the bridge. This should always be followed up by allowing the unit to use up any remaining salt and then thoroughly cleaning out the brine tank.

Allow four hours to produce a brine solution, then manually regenerate the softener.

Figure 7

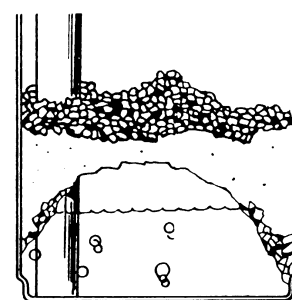

## Care of Your Softener

To retain the attractive appearance of your new water softener, clean occasionally with mild soap solution. Do not use abrasive cleaners, ammonia or solvents. Never subject your softener to freezing or to temperatures above 110°F (43°C).

## Cleaning the Injector Assembly (Figure 8)

Sediment, salt and silt will restrict or clog the injector. A clean water supply and pure salt will prevent this from happening.

The injector assembly is located on the right side of the control valve. This assembly is easy to clean.

Shut off the water supply to your softener and reduce the pressure by opening a cold soft water faucet. Using a screwdriver, remove the two screws holding the injector cover to the control valve body. Carefully remove the assembly and disassemble as shown in Figure 8. The injector orifice is removed from the valve body by carefully turning it out with a large screwdriver. Remove the injector throat the same way. Carefully flush all parts including the screen. Use a mild acid such as vinegar or Pro-Rust Out to clean the small holes in the orifice and throat.

Reassemble using the reverse procedure.

Figure 8

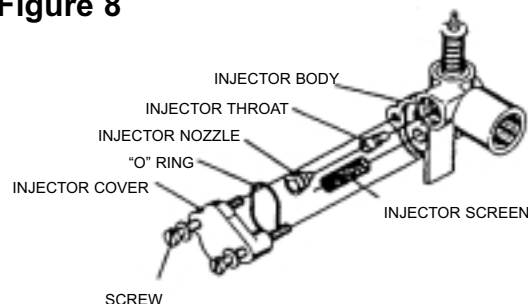

## Resin Cleaner

An approved resin cleaner **must** be used on a regular basis if your water supply contains iron. The amount of resin cleaner and frequency of use is determined by the quantity of iron in your water (consult your local representative or follow the directions on the resin package).

# Trouble Shooting Guide

Before calling for service, follow the steps below, then MANUALLY REGENERATE your softener.

PROBLEM	CAUSE	CORRECTION
1. Softener delivers hard water	<ul style="list-style-type: none"> <li>A. Bypass valve is open</li> <li>B. No salt in brine tank</li> <li>C. Insufficient water flowing into brine tank</li> <li>D. Salt bridged</li> <li>E. Loose brine line</li> <li>F. Plugged injector assembly</li> </ul>	<ul style="list-style-type: none"> <li>A. Close bypass valve.</li> <li>B. Add salt to brine tank and maintain salt level above water level.</li> <li>C. Check salt setting and clean brine line flow control if plugged.</li> <li>D. Break salt bridging – see page 6.</li> <li>E. Tighten connections at control valve and at brine valve.</li> <li>F. Clean/replace injectors and screen.</li> </ul>
2. Intermittent soft water	<ul style="list-style-type: none"> <li>A. Control will not draw brine properly</li> <li>B. Using hot water during regeneration cycle</li> <li>C. Incorrect salt setting</li> <li>D. Softener capacity too small</li> </ul>	<ul style="list-style-type: none"> <li>A. Maintain water pressure at 20 psi minimum. Check for restrictions in drain line. Clean or replace injector assembly. Check for air leaks between control valve and air check valve and tighten connections.</li> <li>B. Avoid using hot water at this time as water heater will fill with hard water.</li> <li>C. Adjust salt setting.</li> <li>D. Increase capacity by replacing with larger unit.</li> </ul>
3. Softener regenerates at wrong time	<ul style="list-style-type: none"> <li>A. Power failure or incorrect setting</li> </ul>	<ul style="list-style-type: none"> <li>A. Restore power and reset time of day.</li> </ul>
4. Unit uses too much salt	<ul style="list-style-type: none"> <li>A. Improper salt setting</li> <li>B. Excessive water in brine tank</li> </ul>	<ul style="list-style-type: none"> <li>A. Check salt usage and salt setting.</li> <li>B. Remove water. Clean drain line flow control, brine line flow control, injector system and brine valve.</li> </ul>
5. Loss of water pressure	<ul style="list-style-type: none"> <li>A. Inlet to control blocked with iron buildup or foreign matter</li> <li>B. Iron buildup in water conditioner</li> </ul>	<ul style="list-style-type: none"> <li>A. Clean line to water softener. Remove piston and clean control.</li> <li>B. Clean control and add resin cleaner to resin bed.</li> </ul>
6. Iron in conditioned water	<ul style="list-style-type: none"> <li>A. Fouled resin bed</li> </ul>	<ul style="list-style-type: none"> <li>A. Check backwash, brine draw and brine tank fill. Clean control and add resin cleaner to resin bed.</li> </ul>
7. Softener fails to draw brine	<ul style="list-style-type: none"> <li>A. Drain line flow control is plugged</li> <li>B. Brine line flow control is plugged</li> <li>C. Injector assembly is plugged</li> <li>D. Line pressure is too low</li> <li>E. Internal control leak</li> </ul>	<ul style="list-style-type: none"> <li>A. Clean drain line flow control.</li> <li>B. Clean brine line flow control.</li> <li>C. Clean/replace injectors and screen.</li> <li>D. Increase line pressure. Line pressure must be at least 20 psi (139.9 KPa) at all times.</li> <li>E. Change seals and spacers and/or piston assembly.</li> </ul>
8. Drain flows continuously	<ul style="list-style-type: none"> <li>A. Foreign material in control</li> <li>B. Internal control leak</li> <li>C. Control valve is jammed in brine or backwash position</li> <li>D. Drive motor stopped or jammed</li> </ul>	<ul style="list-style-type: none"> <li>A. Remove piston assembly and inspect bore, remove foreign material and check control in various regeneration positions.</li> <li>B. Replace seals and/or piston assembly.</li> <li>C. Replace piston and seals and spacers.</li> <li>D. Replace drive motor.</li> </ul>
9. Softener fails to regenerate	<ul style="list-style-type: none"> <li>A. No salt in brine tank</li> <li>B. Injector assembly plugged</li> <li>C. Salt bridged</li> <li>D. Insufficient salt used per regeneration</li> <li>E. Softener capacity too small</li> </ul>	<ul style="list-style-type: none"> <li>A. Add salt.</li> <li>B. Clean/replace injectors and screen.</li> <li>C. Break salt bridging – see page 5.</li> <li>D. Check and adjust salt setting.</li> <li>E. Replace softener with larger unit.</li> </ul>
10. Softener regenerates every night	<ul style="list-style-type: none"> <li>A. Softener capacity too small</li> </ul>	<ul style="list-style-type: none"> <li>A. Replace with larger unit.</li> </ul>





# **GUARANTEE**

**HYDROTECH** guarantees that your new water conditioner is built of quality material and workmanship. When properly installed and maintained, it will give years of trouble-free service.

## **FIVE YEAR COMPLETE PARTS GUARANTEE**

**HYDROTECH** will replace any part which fails within 60 months from date of manufacture, provided the failure is due to a defect in material or workmanship. The only exception shall be when proof of purchase or installation is provided and then the warranty period shall be from the date thereof.

## **TEN YEAR GUARANTEE ON MINERAL AND BRINE TANKS**

**HYDROTECH** will provide a replacement mineral or brine tank to any original equipment purchaser in possession of a tank that fails within 120 months, provided that the water conditioner is at all times operated in accordance with specifications and not subject to freezing or exposure to direct sunlight.

## **GENERAL PROVISIONS**

**HYDROTECH** assumes no responsibility for consequential damage as a result of escaped water from the water filter; labor or expense incurred as a result of a defect or for failure to meet the terms of these guarantees because of circumstances beyond its control.