



# **5600 Calendar Clock Valve**

---

## **Combination Organic Color Removal & Softener Operation Manual**



# Performance and Specifications

Item Number	Model Number	Softening Capacity (kilograins) @10lb/cf <sup>(1)</sup>	Color Removal Capacity (ppm-gallons) @10lb/cf <sup>(1)</sup>	Service Flow Rate <sup>(2)</sup> USGPM (LPM)	Maximum Flow to Drain USGPM (LPM)	Mineral Tank Size <sup>(3)</sup> inches (mm)	Brine Tank Size <sup>(3)</sup> inches (mm)	Resin Volume cu.ft. (litres)	Anion Resin Volume cu.ft. (litres)	Salt Capacity Lbs. (kg)	Shipping Weight Lbs. (kg)
7377	WTCA45	12	2,000	8 (30.3)	2.4 (9.1)	10 x 54 (254 x 1372)	22 x 38 (559 x 965)	0.50 (14)	1.00 (28)	420 (191)	100 (45)

**Caution:** These water conditioners are not intended to be used for treating water that is microbiologically unsafe or of unknown quality without adequate disinfection before or after the system.

**Notes:**

**Operating Temperature Range:** 110°F (43°C)  
**Operating Pressure Range:** 100 psig (689 kPa)  
**Electrical:** Standard 110V  
**Pipe size:** 3/4"

1. "\*\*" designates that 10 lb/cf is the factory salt setting for all units.
2. Capacities of softeners may deviate from the chart above depending on flow rates and raw water conditions.
3. The manufacturer reserves the right to make product improvements which may deviate from the specifications and descriptions stated herein without obligation to change previously manufactured products or to note the change.
4. 1 Kilograin is equal to 1000 grains.

## Application and Installations for the Combination OCR Removal & Softener Unit

This Combination Softener has been designed to remove tannins and hardness from your water supply. Tannins can cause a yellow to brown colour in the water (i.e. organic colour) and also may impart taste and odour as well. Tannins are formed by the decomposition of vegetable matter. Hardness is responsible for the deposition of calcium carbonate scale in pipes and equipment.

All tannins are not equal, the unit selected should have been with the assistance of an authorized representative or distributor. This is typically done based on a water analysis and column testing of the source water and/or with experience on other successful installations in the area on the same source water.

### **Application Notes about Combination OCR Removal & Softener Unit:**

1. Although the Combination unit was selected using the source water, the selected Combination unit was the most suitable for this application, total removable of all colour contaminants may occasionally not be attained due to:
  - a) Multiple types of tannins in the source water. Unit media may only be successful at removing some of these organics, but not all.
  - b) Colour may be caused by contaminants other than organics.
  - c) The remaining contaminants may require removal by other methods such as activated carbon, reverse osmosis, etc. Please consult your authorized representative or distributor for solutions.
2. Metals in the water such as Iron and Manganese can also foul the Combination resin bed, reducing the ability to remove tannins and hardness. An iron filter or iron guard softener should be used to reduce the problem causing contaminants to an acceptable level.  
**(Installation Tip: Ensure that the Combination unit is only allowed to regenerate after the regeneration of the filter unit, if one is present.)**
3. Turbidity caused by suspended solids and sediment can foul the Combination resin bed. Removal of the turbidity can be achieved through some type of mechanical filtration such as a multi-media filter and/or cartridge filters.
4. Depending on the alkalinity of the source water being treated, the pH (alkalinity) of the water after the Combination unit will likely drop for part or all of the units service run after regeneration. This is caused by the Combination unit's resin ability to also remove alkalinity in the water. Adjustment of the waters pH may be required once treated by the Combination unit.
5. If "nitrates" are present in the source water, consult your authorized representative or distributor for additional solutions.  
**(Caution: This unit has not been designed for nitrate removal and should be dealt with separately.)**
6. Occasionally, a fishy odour will occur if the source water is of a high pH, typically greater than 8.0. If this occurs, putting the unit through a couple regeneration cycles can sometimes reduce the odour. Chlorine in combination with a higher pH can also make the odour worse or more difficult to overcome as chlorine degrades the resin in the Combination unit.
7. Depending on the alkalinity of the source water being treated, the chlorides in the treated water from the Combination unit will increase proportionally. This may result in a bitter salty taste which should be treated with a reverse osmosis drinking water system for household drinking and cooking water.

# Installation Instructions

## CAUTION:

If the ground from the electrical panel or breaker box to the water meter or underground copper pipe is tied to the copper water lines and these lines are cut during installation of the Noryl bypass valve and/or poly pipe, an approved grounding strap must be used between the two lines that have been cut in order to maintain continuity. The length of the grounding strap will depend upon the number of units being installed and/or the amount of copper pipe being replaced with poly. See Figure 1.

In all cases where metal pipe was originally used and is later interrupted by poly pipe or the Noryl bypass valve as in Figure 1 or by physical separation as in Figure 2, to maintain proper metallic pipe bonding, an approved ground clamp c/w not less than #6 copper conductor must be used for continuity.

Check your local electrical code for the correct clamp and cable size.

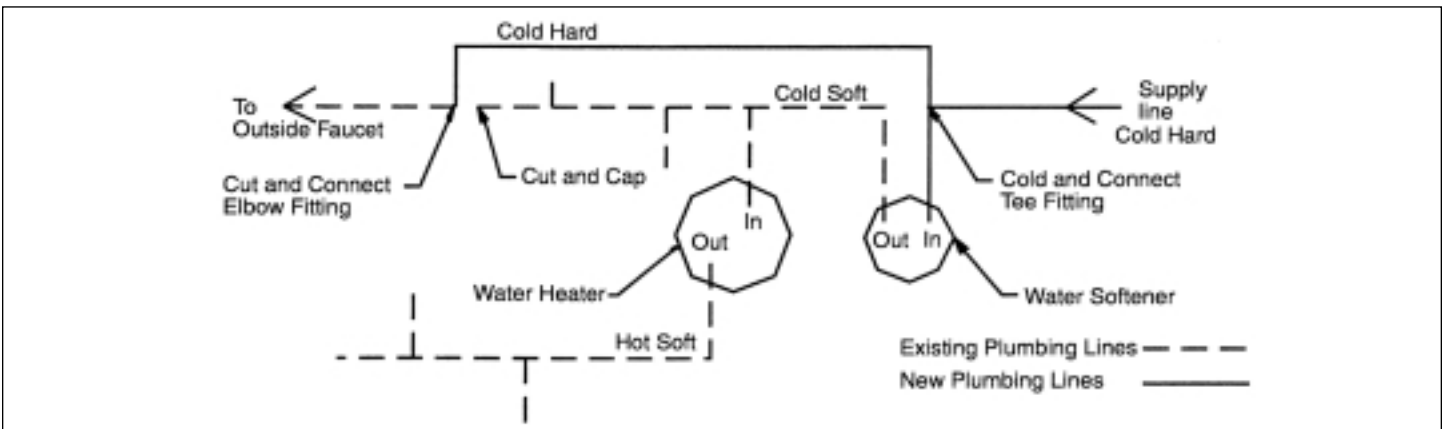
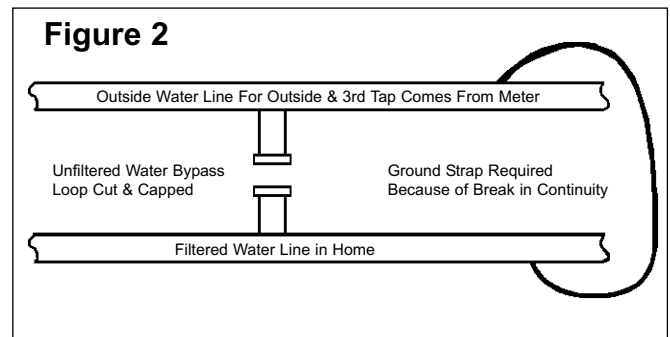
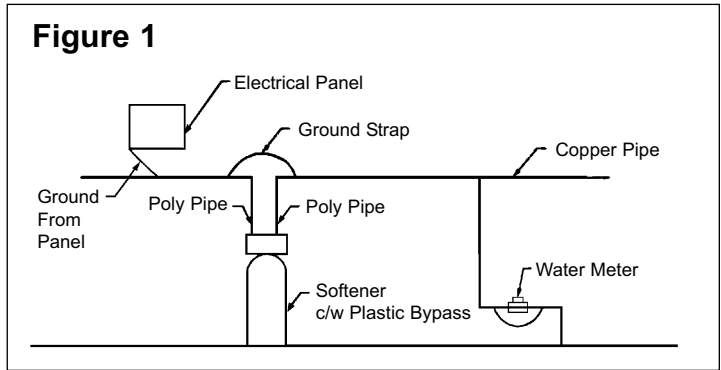

1. Determine the best location for your water softener, bearing in mind the location of your water supply lines, drain line and 110 volt AC electrical outlet. Subjecting the softener to freezing or temperatures above 110°F (43°C) will void the warranty.
2. Water to supply outside faucets used to water lawns and gardens should not be softened. A new water line is often required to be connected to supply hard water to the inlet of the water softener and to the outside faucets. Cut the water line between where it enters the house; before any lines that branch off to feed the hot water heater or other fixtures in the house; and as near the desired location of the water softener as possible. Install a tee fitting on the feed end of the cut pipe and an elbow fitting on the other end. Install piping from the tee to the inlet of the water softener and from the elbow to the outlet to the softener. To serve the water lines which branch off to feed outside faucets, cut the branch lines approximately two inches from the fitting on the main water line. Install an elbow on the end of the pipe nearest the outside faucet and a cap on the end connected to the existing water line. Install piping from the tee on the inlet to the water softener to the elbow on the pipe to the outside faucet. Following this procedure will result in all lines in the house, with the exception of the outside faucets but including the water heater and therefore the hot water lines, being supplied with soft water.
3. Familiarize yourself with the location of the inlet, outlet and drain on the control valve. Be very careful not to get the controls wet.

- Attach the bypass valve to the control valve. Connect the inlet and outlet of the water softener to the plumbing in the house. The control valve must not be subjected to temperatures above 71°C (160°F). To avoid damaging the control valve when sweat fittings are used, solder the threaded copper adapters to the copper pipe and then, using teflon tape, screw the assembly into the bypass valve.

**CAUTION** - do not use pipe thread compound as it may attack the material in the valve body.

- Using teflon tape, screw the 1/2" hose barb into the drain port in the valve. Attach 1/2" drain hose to the hose barb and tighten securely with a hose clamp. Run the drain line to a floor drain or a laundry drain. Complete any necessary plumbing.
- On the twin tank units, pull the 3/8" brine line through the hole in the side of the brine tank. Connect the brine line to the fitting on the side of the valve using the nut and ferrule. Tighten snugly.

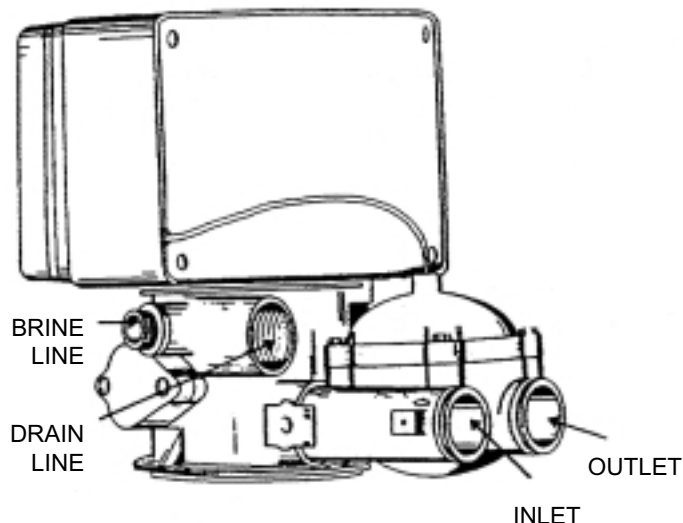

**Rear View - Plumbing Hook-Up**

- Make sure the bypass valve is in the service position.
- Set the time of day and the program wheel according to the instructions on page 4.
- Remove back cover plate. Make sure that the salt dosage is set as recommended on page 5.  
NOTE: The various regeneration positions may be dialed manually by turning the large knob on the front of the control clockwise, until the indicator shows the desired position.
- Turn the large knob to the backwash position. Turn on the water supply to the valve and wait until water starts running at the drain. Allow the water to run at the drain for 2 to 3 minutes.
- Turn the knob advancing the valve to the brine and rinse position. Allow the water to run at the drain for a further 2 to 3 minutes. Using the same procedure, turn the knob to rapid rinse position and allow to run for a few minutes.
- Plug the conditioner in. Manually turn the knob to the start of the brine refill position. The correct amount of water will be automatically metered through the air check tube in the brine well into the brine tank, and the control will automatically return to the service position. The service position is indicated by the word SERVICE on the front dial.
- Replace back cover on the control module.
- Put a minimum of 40 kg of crystal water softener salt in the brine tank. The unit will automatically fill to the correct level when it regenerates.

**Optional Sanitization Procedure:** We recommend that all new water conditioners be disinfected as part of the startup. Sanitization is achieved by the application of chlorine in the regeneration cycle of the conditioner. A liquid solution of 5.25% sodium hypochlorite (commonly referred to as household bleach) is recommended as a suitable disinfectant. Use only unscented products. For every cubic foot of resin in the softener, pour approximately two (2) tablespoons of sodium hypochlorite into the brine well tube. The brine tank refill in Step 12 should add the correct amount of water to the brine tank. If not, the water can be added manually now. Press and hold the EXTRA CYCLE button to begin a manual regeneration. Press the EXTRA CYCLE button again to advance the valve to the Brine/Rinse position. Allow softener to complete the Brine/Rinse cycle, then let the manual regeneration continue until the brine tank is refilled again with the correct amount of water.

**ALL STATE AND LOCAL GOVERNMENT CODES GOVERNING INSTALLATION OF THESE DEVICES MUST BE OBSERVED.**

# Operating Instructions

## Setting the Time of Day (Figure 3)

This is a 24-hour timer and must correspond with the correct time on your wrist watch to ensure proper cycling of your conditioner. Disengage the drive gear by pressing and holding in the RED BUTTON on the left side of the control. Now turn the large 24-hour gear until the actual time of day is at the time of day arrow at the bottom of the panel. Release the red button to re-engage the drive gear. The correct time of day on the 24-hour clock has now been set.

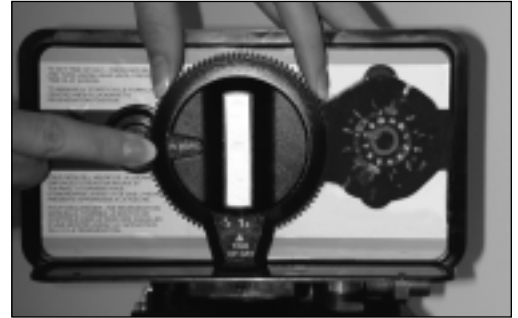

Figure 3

## Time of Regeneration

The time of regeneration is factory set at 2:00 a.m.

## Manual Regeneration Cycle (Figure 4)

Should you run out of soft water due to inadequate frequency of regeneration or inadequate reserve capacity, power failure, lack of salt, or excessive usage because of unexpected company, you can initiate a manual regeneration simply by turning the manual regeneration knob on the front of the control to "REGEN" position. The conditioner will now automatically complete a regeneration cycle and return to service. Be sure there is adequate salt and salt brine in the brine tank for a satisfactory regeneration.



Figure 4

## Setting the Regeneration Frequency (Figure 5)

The unit's control features a skipper wheel with twelve numbered tabs and trip fingers. Each represents one day of a twelve day schedule. By adjusting the skipper wheel tabs the control can be programmed to regenerate every second, third, fourth, sixth or every twelfth day, according to your requirements.

The control is shipped with all the skipper wheel tabs pushed outwards. You must push the tabs in toward the center of the wheel (retracting the trip fingers) for each day that regeneration is **not** required.

Rotate the skipper wheel until number "1" is at the pointer, leave this tab out. Moving clockwise round the skipper wheel, push in tabs for those days regeneration is **not** required. The tabs left out trigger regeneration, these should be evenly spaced around the wheel.

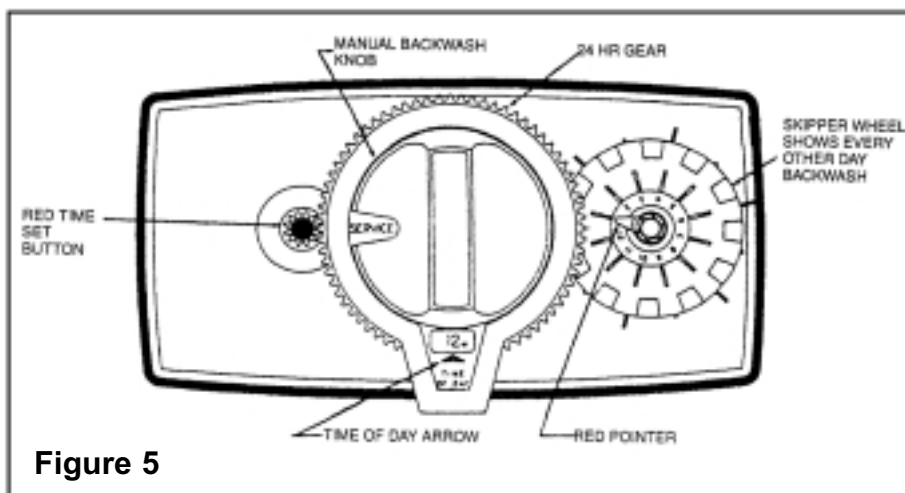

Figure 5

**Important Note - Due to the nature of the interaction between the colour producing organic molecules and the resin bed in your Combination unit, we recommend the unit be regenerated a minimum of every 3 days. This is to extend the life of the resin bed in your Combination unit.**

## Salt Settings are factory set and should not need adjustment

WTCA45.....8 lbs

## Automatic Bypass

The regeneration cycle lasts approximately 2-1/2 hours, after which soft water service will be restored. During regeneration, hard water is automatically bypassed for use in the household. Hot water should be used as little as possible during this time to prevent hard water from filling the water heater. This is why automatic regeneration is set for sometime during the night and manual regenerations should be performed when little or no water will be used in the household.

## Safety Float

The brine tank is equipped with a safety float which prevents your brine tank from overflowing as a result of a malfunction such as a power failure.

## Water Pressure

Your softener is designed to operate under normal water pressures from 20 psi (1.4 atm) to 120 psi (8.2 atm).

## New Sounds

You may notice new sounds as your water softener operates. The regeneration cycle lasts approximately 2-1/2 hours. During this time, you may hear water running intermittently to the drain.

## Manual Bypass (Figure 6)

In the case of emergency, such as an overflowing brine tank, you can isolate your water softener from the water supply using the bypass valve located at the back of the control.

In normal operation the bypass is open with the on/off knobs in line with the inlet and outlet pipes. To isolate the softener, simply rotate the knobs clockwise (as indicated by the word BYPASS and arrow) until they lock.

You can use your water related fixtures and appliances as the water supply is bypassing the softener. However, the water you use will be hard.

To resume soft water service, open bypass valve by rotating the knobs counter-clockwise.

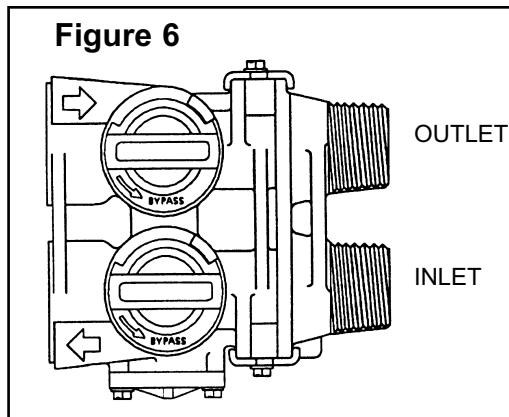

# Maintenance

## Checking the Salt Level

Check the salt level monthly. Remove the lid from the cabinet or brine tank, make sure salt level is always above the brine level (you should not be able to see water).

## Adding Salt

Use only clean salt labeled for water conditioner use, such as crystal, pellet, nugget, button or solar.

The use of rock salt is discouraged because it contains insoluble silt and sand which build up in the brine tank and can cause problems with the system's operation. Add the salt directly to the tank, filling no higher than the top of the brine well.

## Caution

Liquid brine will irritate eyes, skin and open wounds - gently wash exposed area with fresh water. Keep children away from your water conditioner.

## Bridging (Figure 7)

Humidity or wrong type of salt may create a cavity between the water and the salt. This action, known as "bridging", prevents the brine solution from being made, leading to your water supply being hard.

If you suspect salt bridging, carefully pound on the outside of the brine tank or pour some warm water over the salt to break up the bridge. This should always be followed up by allowing the unit to use up any remaining salt and then thoroughly cleaning out the brine tank.

Allow four hours to produce a brine solution, then manually regenerate the softener.

Figure 7

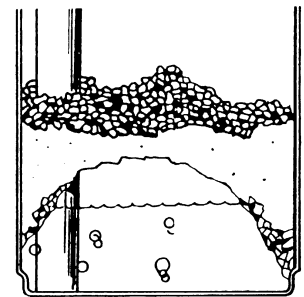

## Care of Your Softener

To retain the attractive appearance of your new water softener, clean occasionally with mild soap solution. Do not use abrasive cleaners, ammonia or solvents. Never subject your softener to freezing or to temperatures above 110°F (43°C).

## Cleaning the Injector Assembly (Figure 8)

Sediment, salt and silt will restrict or clog the injector. A clean water supply and pure salt will prevent this from happening.

The injector assembly is located on the right side of the control valve. This assembly is easy to clean.

Shut off the water supply to your softener and reduce the pressure by opening a cold soft water faucet. Using a screwdriver, remove the two screws holding the injector cover to the control valve body. Carefully remove the assembly and disassemble as shown in Figure 8. The injector orifice is removed from the valve body by carefully turning it out with a large screwdriver. Remove the injector throat the same way. Carefully flush all parts including the screen. Use a mild acid such as vinegar or Pro-Rust Out to clean the small holes in the orifice and throat.

Reassemble using the reverse procedure.

Figure 8

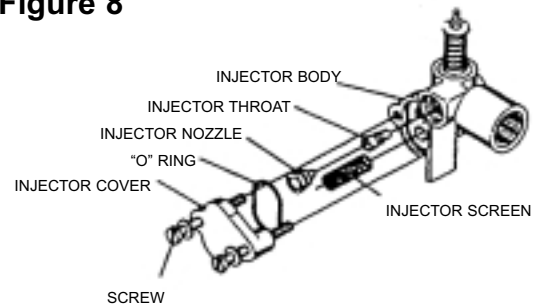

## Resin Cleaner

An approved resin cleaner **must** be used on a regular basis if your water supply contains iron. The amount of resin cleaner and frequency of use is determined by the quantity of iron in your water (consult your local representative or follow the directions on the resin package).

## Trouble Shooting your Combination Softener Unit

<p><b>Problem: Fishy or unpleasant odour is apparent in the treated water that is not present in the untreated water.</b></p>	
<p>1. pH of the incoming water may be high.</p>	<ul style="list-style-type: none"> <li>This odour may be apparent on startup and will typically be reduced or eliminated after a couple service runs and regenerations cycles of the Combination Softener unit.</li> </ul>
<p>2. pH of the incoming water maybe high in combination with chlorine present for disinfection.</p>	<ul style="list-style-type: none"> <li>The addition of chlorine along with high pH typically increases the chances that an odour will be present in the treated water With the presence of chlorine, it is unlikely odour will be eliminated. Chlorine can be removed through the use of an activated carbon filter, however it is highly recommended that additional disinfection methods be re-employed downstream of the Combination Softener unit with Ultraviolet Sterilizers or Chlorination Pumps.</li> </ul>
<p><b>Problem: Combination Softener unit was removing colour from water, but then starts to show colour again until regeneration. Then colour is removed again.</b></p>	
<p>1. Capacity of Combination Softener unit is being over run and resulting in tannins not being removed near the end of service run.</p>	<ul style="list-style-type: none"> <li>Decrease the gallons between service runs to a point where no coloured water is appearing between one regeneration to the next.</li> </ul>
<p><b>Problem: Combination Softener unit was removing colour from water, but then starts to show colour earlier and earlier into service run.</b>  <b>OR</b>  <b>Problem: Combination Softener unit was removing colour from water, but no longer seems to be effective.</b></p>	
<p>1. Regeneration is not being performed adequately.</p>	<ul style="list-style-type: none"> <li>Check to see if salt is in brine tank. If no salt is present, last regeneration(s) may have been done without salt brine. Add salt to brine tank and manually regenerate Combination Softener unit until after allowing brine to dilute in water for at least 4 hours.</li> <li>Check to see if brine tank is being refilled with water properly at the end of the regeneration cycle and/or if water is being drawn into the valve during the brine draw cycle. Injector &amp; Screen or Brine Valve may be plugged and require cleaning.</li> <li>Check to see that valve settings are correct.</li> </ul>
<p>2. Regeneration is not being performed at all.</p>	<ul style="list-style-type: none"> <li>Check gallonage setting between regenerations. Capacity set may be too large.</li> <li>Check to see that meter is turning and properly connected via the meter cable to the timer.</li> <li>Check to ensure that Bypass Valve is not open and bypassing the Combination Softener unit with untreated water.</li> </ul>
<p>3. Resin Media may be backwashing to drain.</p>	<ul style="list-style-type: none"> <li>Confirm backwash flow control is installed on drain line and check that backwash flow control has not been swapped for service line flow control.</li> <li>Monitor drain line during regeneration cycle and check that no resin beads are exiting the Combination Softener unit.</li> </ul>
<p>4. Combination Softener unit resin media may be fouled with organics. Check resin visually to confirm.</p>	<ul style="list-style-type: none"> <li>Try manually regenerating Combination Softener unit two or three times in a row. Allowing approximately four (4) hours between regenerations to allow salt brine to be saturated.</li> </ul>

<p>4. Cont'd...</p>	<ul style="list-style-type: none"> <li>• As a last resort, try adding approximately four (4) ounces of household bleach (5.25%) into the brine well. Begin a manual regeneration. Monitor the drain line for a strong chlorine odour which should occur in the brine draw cycle . When odour is present, halt regeneration by unplugging unit and shutting down water flow to the unit via the bypass valve. Shutdown the unit for approximately two (2) hours, then continue regeneration by plugging unit back in and replacing bypass valve to service position. Only try this step as a last resort as chlorine will degrade the resin bed. If unsuccessful, see next step.</li> <li>• Resin bed may have become permanently fouled due to infrequency of regenerations or nature of tannins causing colour in water. Replace resin media bed and check to see that regeneration frequency is adequate or consult your dealer.</li> </ul>
<p>5. Combination Softener filter resin media may be fouled with Iron. Check visually to confirm.</p>	<ul style="list-style-type: none"> <li>• Iron should typically be removed prior to the unit. Install an iron filter upstream of the unit.</li> <li>• Clean iron from resin media bed with a reducing agent such as sodium bisulfite or sodium hydrosulfite by adding it to the brine tank down the brine well and allowing time to mix. Manually regenerate softener.  <b>Recommended Product: PRO RUST OUT –</b>  see instructions on bottle on cleaning of water softeners.</li> <li>• If resin bed cannot be cleaned, it may be permanently fouled with iron. Replace resin media bed and install treatment upstream of unit to remove iron.</li> </ul>
<p>6. Combination Softener filter resin media may be fouled with Calcium Carbonate.</p>	<ul style="list-style-type: none"> <li>• Calcium Carbonate fouling is the result of hardness precipitating onto the resin media.</li> <li>• Clean calcium carbonate from resin media with a mild acid solution such as phosphoric acid. Do this by adding cleaning product to the brine tank via the brine well and then manually regenerate. Once complete, manually regenerate again with salt brine.  <b>Recommended Product: PRO Res-Care –</b>  see instructions on bottle on cleaning of water softeners.</li> </ul>

**Problem: Combination Softener unit appear to be causing a high pressure drop in home water system.**

<p>1. Pressure drop may be due other factors.</p>	<ul style="list-style-type: none"><li>• Confirm pressure loss is due to the unit, and not the result of distribution or well pump problem.</li><li>• Confirm pressure loss is due to unit by checking flow while in BYPASS mode.</li><li>• Check that flow demand is not exceeding rated flow rate of Combination Softener unit. These units are supplied with a SERVICE LINE FLOW CONTROL to ensure maximum effectiveness is maintained. Attempting to exceed this flow control rating will result in a pressure drop. Combination Softener unit should be increased in size to compensate for larger demand.</li></ul> <p><b>NOTE: Do not remove this FLOW CONTROL from valve outlet. It will likely result in a decrease in Combination Softener unit performance.</b></p>
<p>2. Pressure loss may be due to fouling from Organics, Iron or Calcium Carbonate.</p>	<ul style="list-style-type: none"><li>• See troubleshooting notes above on dealing with fouling problems.</li></ul>
<p>3. Pressure loss may be due to Resin Media being plugged with Silt and Turbidity.</p>	<ul style="list-style-type: none"><li>• Try manually regenerating the unit and extending the backwash by unplugging unit during the first cycle that begins to send water to the drain. Monitor water to the drain and watch for dirt and silt. If present, continue this backwash cycle until water runs clear then plug unit and allow valve to finish regeneration normally.</li><li>• Install multi-media filter or 5 micron cartridge filter ahead of the unit to remove Silt and Turbidity.</li></ul>

**Problem: Combination softener unit appears to be removing most of the colour in the water, but some still passes through.**

<p>1. Raw water may be partially slipping past Combination Softener unit or the Organics (Tannins) not being removed may be impervious to the resin media in the Combination Softener unit.</p>	<ul style="list-style-type: none"><li>• Check to see that SERVICE LINE FLOW CONTROL is in place on the valve outlet. Flowrates higher than recommended through the unit may be causing some leakage of colour.</li><li>• Check to see that BYPASS valve is not partially open and bleeding some raw water to distribution lines.</li><li>• Check that pipelines after the unit are not lined with organics that are slowly being stripped away. Lines may require flushing.</li><li>• If all equipment and distribution sources of problem have been eliminated, consult your water treatment dealer, who may try to “polish” the remaining colour after the the unit with an ACTIVATED CARBON filter or cartridges or other treatment method.</li></ul>
---	--

# **GUARANTEE**

**HYDROTECH** guarantees that your new water conditioner is built of quality material and workmanship. When properly installed and maintained, it will give years of trouble-free service.

## **FIVE YEAR COMPLETE PARTS GUARANTEE**

**HYDROTECH** will replace any part which fails within 60 months from date of manufacture, provided the failure is due to a defect in material or workmanship. The only exception shall be when proof of purchase or installation is provided and then the warranty period shall be from the date thereof.

## **TEN YEAR GUARANTEE ON MINERAL AND BRINE TANKS**

**HYDROTECH** will provide a replacement mineral or brine tank to any original equipment purchaser in possession of a tank that fails within 120 months, provided that the water conditioner is at all times operated in accordance with specifications and not subject to freezing or exposure to direct sunlight.

## **GENERAL PROVISIONS**

**HYDROTECH** assumes no responsibility for consequential damage as a result of escaped water from the water filter; labor or expense incurred as a result of a defect or for failure to meet the terms of these guarantees because of circumstances beyond its control.